

Air parking heater

Technical description, installation, operation
and maintenance instructions.

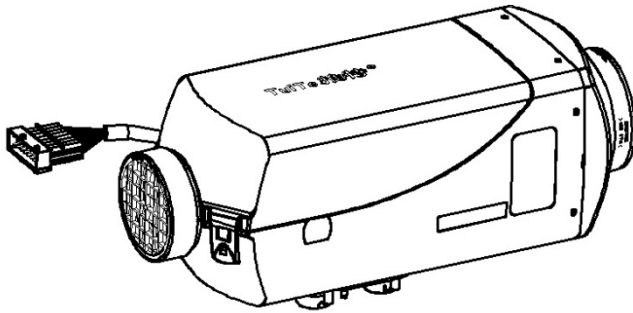

Product type	Order No.
Diesel 2.2KW 12V	4A2002 12C21
Diesel 2.2KW 24V	4A2002 24C21
Diesel 4KW 12V	4A2004 12C21
Diesel 4KW 24V	4A2004 24C21

Air heater for operating independently of the engine.

Nov 16th,2020
Plateau version

Preface

Thank you for choosing air parking heater.

This instruction book describes the structures, working principles, installation and operation of the parking heater. For correct use of the heater, please read this instruction book carefully before installation and use. The instruction book shall be saved in a convenient place for later reference.

Attention:

- This instruction book is subject to revision without notice, but the instruction book is in conformity to the purchased product.
- Our effort is to explain all questions the users may have through this instruction book. If you have any doubts or find anything incorrect in this instruction book, please contact our company directly.
- At first unpacking, please check the heater and its accessories against the packing list. Please contact the dealer immediately if any problem is found.
- If any trouble arises during application, please contact the Department of Marketing of our company or other customer service stations authorized by our company. We shall do our best to provide service to you.

Note: Comply with the operational manual for installation and use to ensure that the heaters can work for a long time.

Version No. 202512

1. Introduction

Application scope

This air heater is not affected by the engine, for in compliance with its heating power under the premise of installation in the following vehicles:

- Various properties of the car (at most 9 people) and its trailer.
- Agriculture working machinery.
- Boats, steamer and yacht (Limited to diesel heaters) .
- Motor homes.

Heater purpose

- Preheating and defrosting the glass.
- Heating and keeping the following warm:
 - Driver and working cabs.
 - Freight compartments.
 - Passenger and crew compartments.
 - Motor homes.

On account of its functional purpose, the heater is not permitted for the following applications:

- Long-term continuous operation, e.g. for preheating and heating of:
 - Residential rooms and garages.
 - Work huts, weekend homes and hunting huts.
 - Houseboats, etc.
- Heating or drying
 - Living creatures (people or animals) by blowing hot air directly at the subject objects.
 - Blowing hot air into containers.

Safety instructions for application and proper purpose!

● Instructions for installation

- Parts of the structure and other components near the heater must be protected from excess heat exposure and possible contamination from fuel or oil
- The heater must not pose a fire hazard even when it overheats. This requirement is deemed to be fulfilled when adequate clearance to all parts is observed during installation, sufficient ventilation is provided and fire-proof materials or heat plates are used.
- All appropriate precautions must be taken when arranging the heater to minimize the risk of injuries to persons or damage to other property.

● Exhaust system

- The exhaust outlet must be arranged so as to prevent any penetration of exhaust fumes into the vehicle interior through the ventilation system, warm air intakes or open windows.

● Combustion air intake

- The air for the heater combustion chamber must not be sucked in from the passenger compartment of the vehicle. The air intake must be arranged or protected in such a way that it cannot be blocked by other objects.

● Heater air intake

-The heater air supply must consist of fresh air or circulated air and be sucked in from a clean area not contaminated by exhaust fumes of the drive machine, the combustion heater or any other source in the vehicle.

-The intake pipe must be protected by a grid or other suitable means.

●Hot air outlet

-The hot air pipes within the vehicle must be arranged or protected in such a way that there is no risk of injury or damage if they are touched.

-The air outlet must be arranged or protected in such a way that it cannot be blocked by any objects.

2. Product information

●Installation components diagram

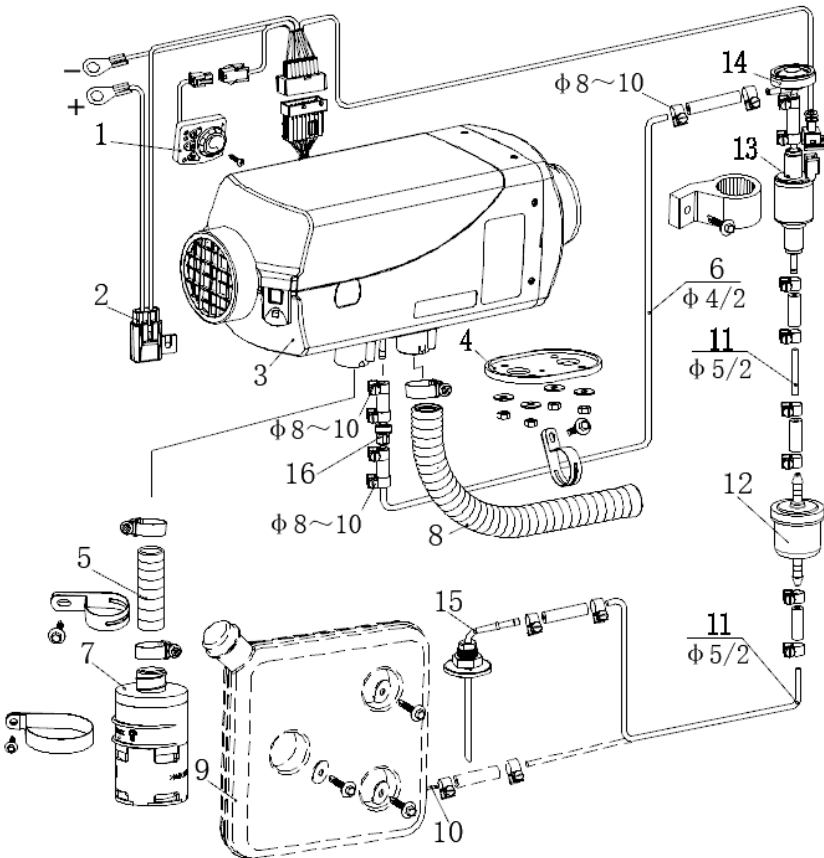

Fig.1

- 1- Control switch 2-Cable harness 3- Heater 4- Gasket 5- Air inlet pipe
- 6- Fuel pipe 7- Air inlet filter (optional) 8- Exhaust pipe 9-Tank (optional)
- 10- Tubing joint (optional) 11- Fuel pipe 12- Filter 13-- Fuel pump
- 14- Damper 15- Fuel suction pipe 16- Non-return valve

Heater Model	FJH-2.2/1C		FJH-2.2/2C	
Technical specification				
Heater grade	Min FJH-4/1C	Max	Min FJH-4/2C	Max
Heater grade (w)	850 Min	2200 Max	850 Min	2200 Max
Fuel	Diesel		Diesel	
Heating value (w)	900	4000	900	4000
Fuel consumption (l/h)	0.1	0.28	0.1	0.28
Power supply	DC12V		DC24V	
Fuel consumption (l/h)	0.1	0.51	0.1	0.51
Run time consumption power	7w DC12V 24w		7w DC24V 24w	
Starting consumption power	8w	34w	8w	34w
Working height above sea level	$\leq 5000m$			
Starting consumption power	$\leq 100w$			
Weight	About 2.7Kg			
Working height above sea level	$\leq 3000m$			
Weight	About 4.5Kg			

Table 2

12V Heater operating voltage range:

10.5V~16V

24V Heater operating voltage range:

21V~32V

FJH-2.2/□C Main dimensions

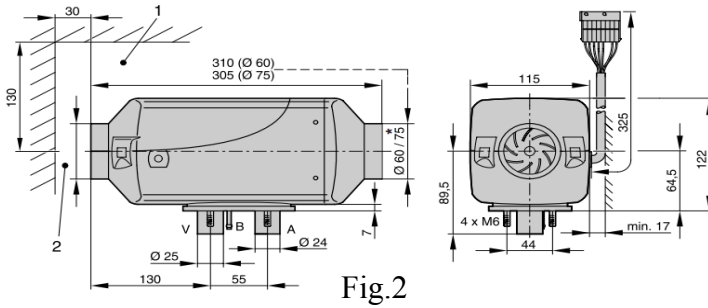

Fig.2

FJH-4/□□ Main dimensions

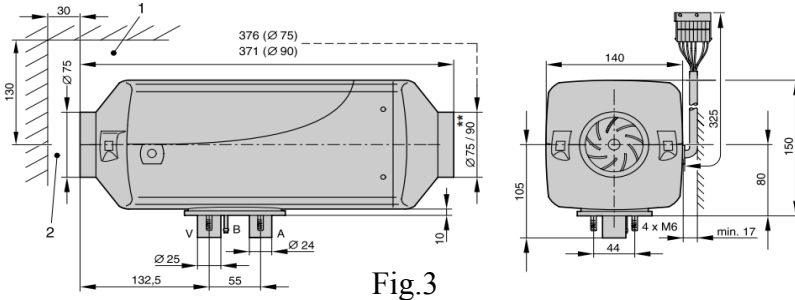

Fig.3

- 1- Minimum installation clearance (space) for opening the lid and for dismantling the glow plug and the controller.
- 2- Minimum installation clearance (space) for intake of heater air.

A=Exhaust
B=Fuel
C=Combustion air

3. Installation

Installation and location

The heater is suitable and certified for installation in parts of vehicles used by persons. Installation in the cab or passenger compartments of coaches or buses with more than 9 seats is not allowed.

When installing in compartments used by persons, the exhaust, combustion air and fuel pipes in these areas must not have any detachable connections and must be routed splash-water proof in the breakthroughs. For this reason, the heater can be mounted with its foot using the flange seal in the foot to the vehicle floor or to an outer wall of the vehicle.

Note

When installing the heater, always make sure there is sufficient clearance left for intake of the heater air and for dismantling the glow plug and controller (See Main dimensions 2)

Installation position in a motor home

In a motor home, the heater is preferably installed in the inner compartment or luggage compartment. If it is not possible to install the heater in the passenger compartment or boot, the heater can also be mounted and protected against splashing water under the vehicle floor.

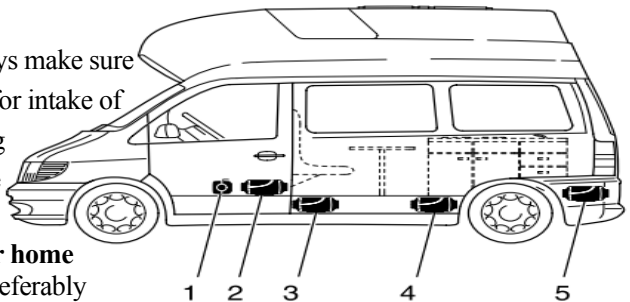

Fig.4

- 1- Heater in front of the passenger seat
- 2- Heater between the driver's seat and the passenger seat
- 3- Heater under the vehicle floor
- 4- Heater under the back seat
- 5- Heater in the boot

Installation in a car or people carrier

In a car or people carrier, the heater is preferably installed in the passenger compartment or boot. If it is not possible to install the heater in the passenger compartment or boot, the heater can also be mounted and protected against splashing water under the vehicle floor.

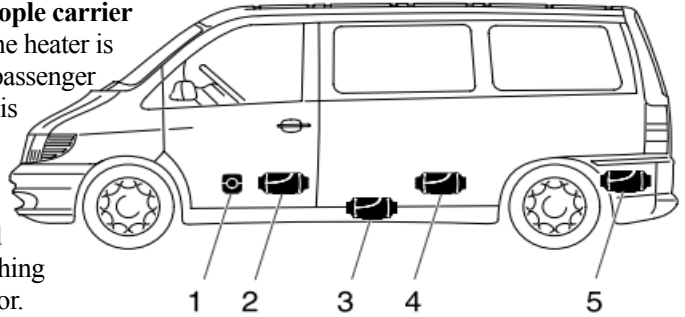

Fig.5

- 1- Heater in front of the passenger seat
- 2- Heater between the driver's seat and the passenger seat
- 3- Heater under the vehicle floor
- 4- Heater under the back seat
- 5- Heater in the boot

Installation in an excavator cab

In an excavator, the heater is preferably installed in the cab. If it is not possible to install the heater in the cab, the heater can also be installed in a storage box outside the cab.

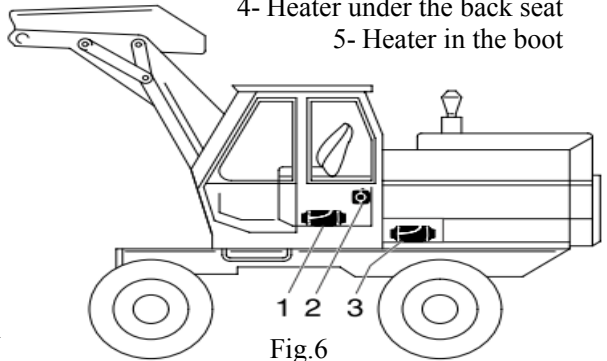
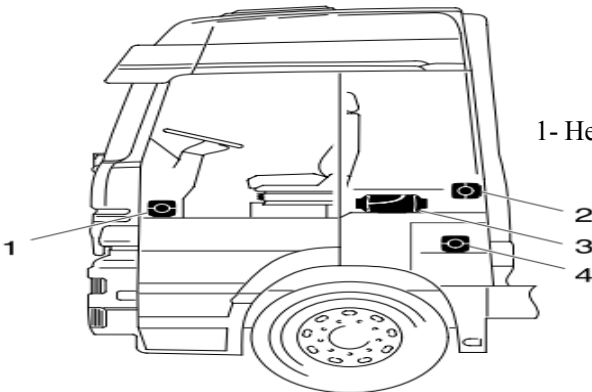

Fig.6

- 1- Heater in the seat box
- 2- Heater on the cab rear wall
- 3- Heater in a protective case

Installation in a truck

In a truck, the heater is preferably installed inside the driver's cab. If it is not possible to install the heater inside the driver's cab, it can also be mounted in the tool box or in a storage box.



- 1- Heater in the passenger's foot room
- 2- Heater on the cab rear wall
- 3- Heater under the bed
- 4- Heater in the tool box

Note

Fig.7

The installation suggestions made in the installation instructions are just examples. Other installation locations are possible as long as they correspond to the installation requirements stated in these instructions.

Possible installation positions

The heater is preferably installing in the normal position as shown in the drawing Fig.8 Depending on the installation conditions, the heater can be tilted by max. 30° (Flow direction to the bottom) or turned by max. 90° around its own longitudinal axis (exhaust connection horizontal, glow plug points upwards!)

In the heating mode, the heater can deviate from the shown normal or maximum installation positions by up to +15° in all directions because of a slanting position of the vehicle or boat, without impaired functions.

Normal position horizontal (exhaust connection downwards) with tolerable swivel range

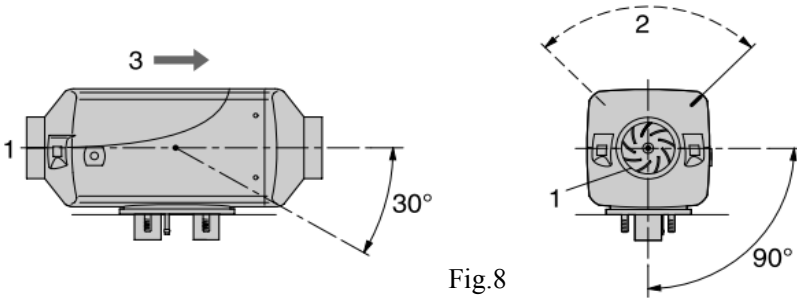

Fig.8

- 1-Heater air intake opening (fan wheel)
- 2-Position of the glow plug
- 3-Direction of flow

Cable harness connection, right or left

If necessary, the cable harness connection can be changed over to the other side of the heater. To do so, the controller has to be removed and the lower semi-circular cable harness cover unclipped. The cable harness can then be rerouted in the controller, then mount the controller again, position in the jacket shell and insert the cable harness bush and the bungs in the corresponding recesses in the lower jacket shell.

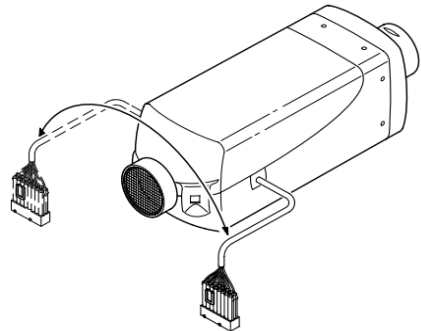
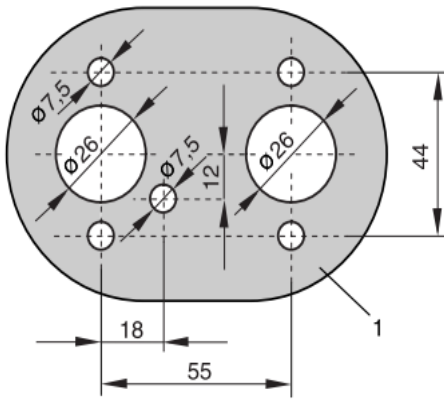

Fig.9

Mounting and fastening

Make the necessary breakthroughs for exhaust, combustion air and fuel as shown in the diagram (Fig.10). The support surface for the heater foot must be flat. The hole $\phi 10.5\text{mm}$ for the cable harness“dosing pump” is not included in the picture drawing and must be drilled after installation.



Contour of the bearing surface
Fig.10

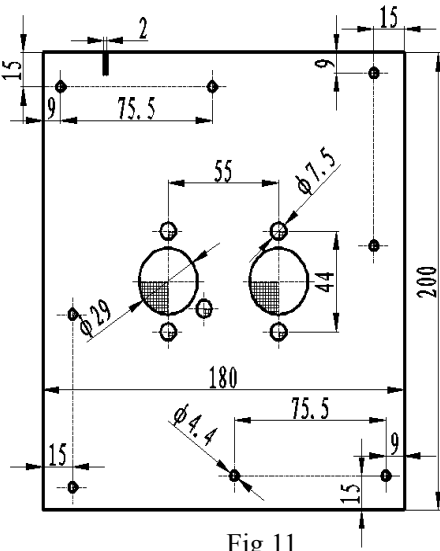
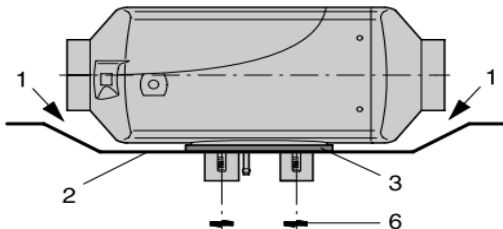

Fig.11

If the sheet metal of the support surface is thinner than 1.5mm, an additional reinforcement plate will have to be fitted. (Fig.11)

Fastening the heater on the vehicle floor



1-There must be sufficient clearance between the heater and the vehicle floor-also check that the fan wheel runs freely

2-The mounting surface must be flat

Heater air system

Risk of burning and injuries

•The hose of the heater air system and the hot air outlet are to be routed in such a way that they pose no temperature risk to people, Animals or materials sensitive to temperature from radiation/contact or blowing directly. If necessary, a cover is to be fitted to the heater air system or hot air outlet.

•The outflow hood must be fitted on the hot air outflow side.

Fastening the heater horizontally to the vehicle wall

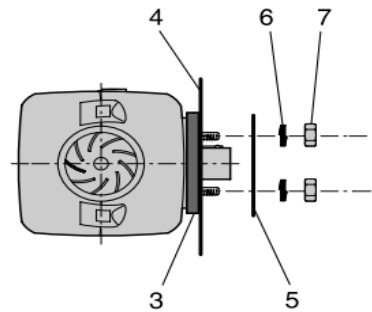

4-Reinforcement plate (if required, see above)

6-Spring washer

7-Hexagon nut M6

A safety grid must be fitted to the heater air intake side and outflow side if no air hoses are mounted to prevent any injuries from the heater air fan or burns from the heat exchanger.

- High temperatures occur in the heater air system during and after the heater has been working. This is why it is important to avoid working in the vicinity of the heater air system while the heater is working. In such cases, switch the heater off beforehand and wait until parts have cooled down completely. If necessary, wear safety gloves.

Note

- The heater air intake opening must be arranged in such a way that under normal circumstances, it is not possible for exhaust from the vehicle engine and heater to be sucked into the system or for the heating air to be contaminated with dust, salt sprayed. For circulating air, position the circulating air intake in such a way that the outflowing hot air cannot be directly sucked in again.

- In the event of possible overheating, it is possible for local hot air temperatures of up to max.150°C or surface temperatures of up to max.90°C to occur immediately before the defect shutdown. Therefore only temperature-resistant hot air hoses approved by us must be used for the heater air system.

- When checking the functions, the mean outflow temperature measured after the heater has been running about 10 minutes at approx.30cm from the outlet should not exceed 110°C(at an intake temperature of approx.20°C).

- If there is a risk of the driver and passengers touching the heater when the vehicle is being driven normally, a contact protection device must be fitted.

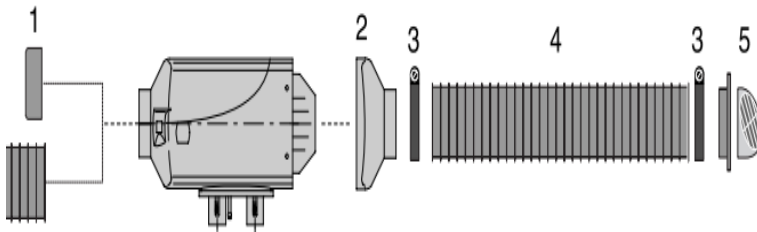

1-Safety grid 2-Outflow hood 3-hose clip
4-Flexible hose 5-Rotating outflow

Fig.14

The optional air duct fittings

Users can choose the air duct fittings according to the situation. Please refer to Fig.15.

No	Name	Specification
A	Grill	$\phi 90$
		$\phi 60$
B	Diameter changes joint	$\phi 90/60$
		$\phi 56/60$
C	Elbow	$\phi 60/90^\circ$
D	Clamp	$\phi 50 \sim 70$
E	Ducting	$\phi 60/\phi 64$
F	Connector	$\phi 60-\phi 60$
G	Reducing T	$\phi 60$

Table 3

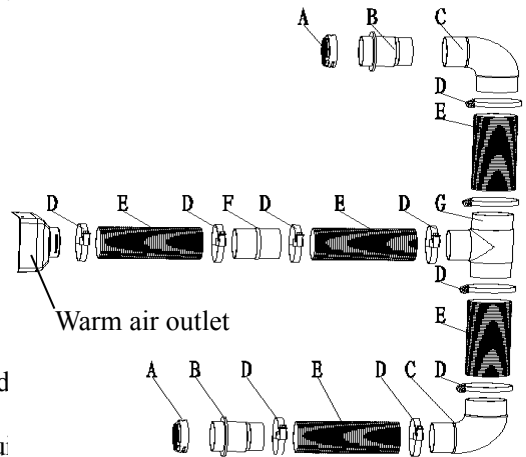

Fig.15

Exhaust system

The flexible exhaust pipe can be shortened on the installation conditions.

Fasten the exhaust silencer (if have) to a surface by cutting off a long part and a short part.

Route the flexible exhaust pipe from the heater to the exhaust silencer and fasten with pipe clips. Use a pipe clip to fix a short exhaust pipe end (with end sleeve) to the exhaust silencer.

Note

The whole exhaust system gets very hot during and immediately after the heater has been working. This is the reason why the exhaust system must be installed according to these instructions.

- The exhaust outlet must end in the open air.
- The exhaust pipe must not protrude beyond the lateral limits of the vehicle.
- Install the exhaust pipe sloping slightly downwards. If necessary, make a drain hole approx. $\phi 5\text{mm}$ at the lowest point to drain off condensation.
- Important functional parts of the vehicle must not be impaired (keep sufficient

clearance).

Mount the exhaust pipe with sufficient clearance to heat-sensitive parts. Pay particular attention to fuel pipes (plastic or metal), electrical cables and brake hoses etc.

- Exhaust pipes must be fastened safely (recommended clearance of 50cm) to avoid damage from vibrations.

- Route the exhaust system so that the emitted fumes are not sucked in with the combustion air.

- The mouth of the exhaust pipe must not get clogged by dirt and snow.

- The mouth of the exhaust pipe must not point in the direction of travel.

Risk of injuries and burns!

Every type of combustion produces high temperatures and toxic exhaust fumes. This is the reason why the exhaust system must be installed according to these instructions.

- Do not perform any work on the exhaust system while the heater is working.

- Before working on the exhaust system, first switch the heater off and wait until all parts have cooled down completely, wear safety gloves if necessary.

- Do not inhale exhaust fumes.

Note

- If a silencer is fitted, the exhaust end pipe must be much shorter than the flexible exhaust pipe between the heater and the exhaust silencer.

- Small arrows indicating the direction of flow have been cast into the fittings to differentiate between the combustion air and the exhaust fittings at the heater.

Combustion air system

The universal installation kit includes a flexible combustion air hose, inner $\varnothing 25\text{mm}$, 600mm long. If necessary the flexible combustion air hose can be shortened by 20 cm or lengthened by max. 2m depending on the installation conditions. Fasten the combustion air hose to the heater clips or cable ties.

In order to meet the dust environment, an optional air filter is a good choice. A length of air filter can be cut in order to meet different thickness of air inlet pipes.

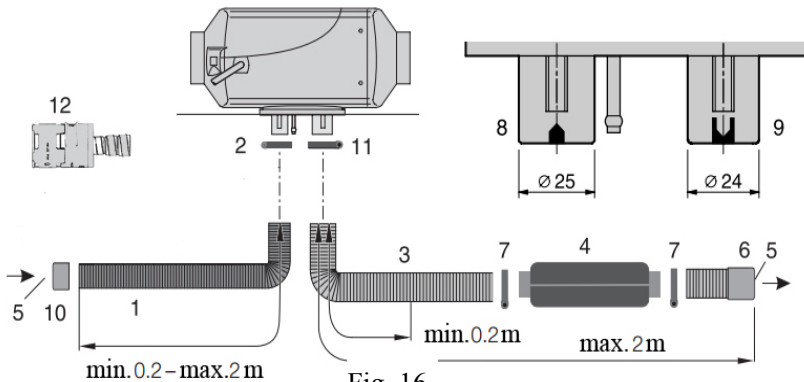

Fig. 16

- | | |
|--|-------------------------------|
| 1-Combustion air hose, di=25mm | 7-Clip |
| 2-Hose clip | 8-Combustion air connection |
| 3-Exhaust pipe, di=24mm | 9-Exhaust connection |
| 4-Exhaust silencer (optional part) | 10-End sleeve, combustion air |
| 5-Intake/outlet opening-protect from wind, snow, dirt and water. | 11-Hose clip |
| 6-End sleeve, combustion air | 12-Air filter (optional part) |

Fig.16

Fuel supply

The following safety instructions must be observed when mounting the dosing pump, routing the fuel pipes and mounting the fuel tank.

Deviations from the instructions stated here are not allowed.

Failure to company can result in malfunctions.

Danger!

Risk of fire, explosion, poisoning and injuries!

Switch off the vehicle engine and heater before refueling and before working on the fuel supply.

- No naked lights when handling fuel.
- Do not smoke.
- Do not inhale fuel vapors.

Note

Safety instructions for routing the fuel pipes

- Only use a sharp knife to cut off fuel hoses and pipes, interfaces must not be crushed and must be free of burrs.

- The fuel pipe from the dosing pump to the heater should be routed at a continuous rise.

- Fuel pipes must be fastened safety to avoid any damage and/or noise production from vibrations(recommended clearance of approx.50cm).

- Fuel pipes must be protected from any mechanical damage.

Route the fuel pipes so that any distortion of the vehicle, engine movements etc. Cannot have any lasting effect on the service life.

- Parts carrying fuel must be protected from interfering heat.

- Never route or fasten the fuel pipes to the heater or vehicle exhaust system. At crossings, always ensure adequate heat clearance, if necessary attach heat deflection plates protective hose.

- Dripping or evaporating fuel must never be allowed to collect on hot parts or ignite on electric systems.

- When connecting fuel pipes with a fuel hose, always mount the fuel pipes in a butt joint to prevent any bubbles from forming.

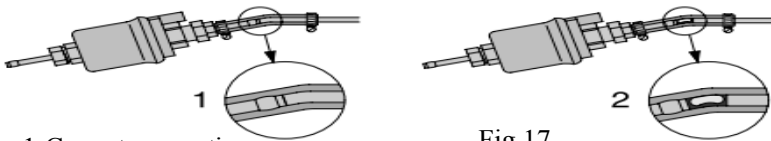

1-Correct connection

2-Incorrect connection-bubble

Fig.17

Safety instructions for fuel pipes and fuel tanks in buses and coaches

- In buses and coaches, fuel pipes and fuel tanks must not be routed through the passenger compartment or driver's cab.

Note

- For noise reasons, do not rigidly fit fuel pipes onto structural sound transferring components.

A sponge rubber hose can be pushed over the fuel tubes for noise reduction.

Installation position of the T-piece

Use the installation positions shown in the diagram 18 when inserting a T-pipe

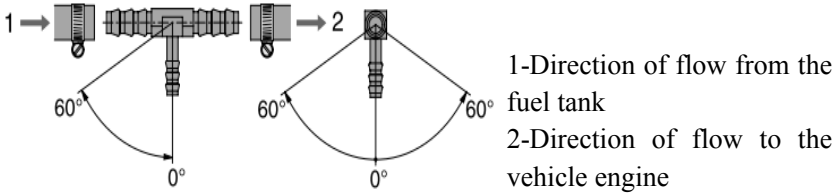

Fig.18

Fuel supply

Fuel suction pipe install in the vehicle tank or independent fuel tank(optional)

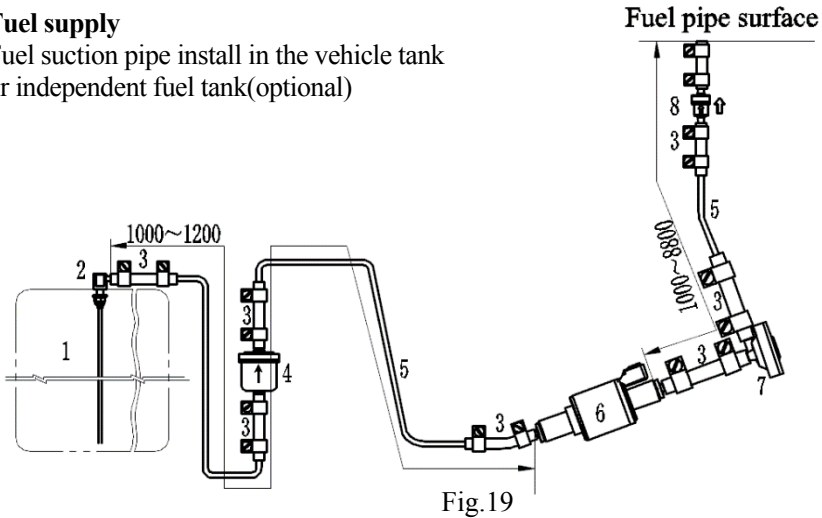

Fig.19

- 1-Fuel tank 2-Fuel extractor 3-Fuel pipe connector 4- Filter
5- Fuel pipe 6-Fuel pump 7-Damper 8-Non-return valve

Installation position of the fuel pump

Always mount the dosing pump with the pressure side rising upwards. Every installation position over 15° is allowed, although an installation position between 15° and 35° is preferable.

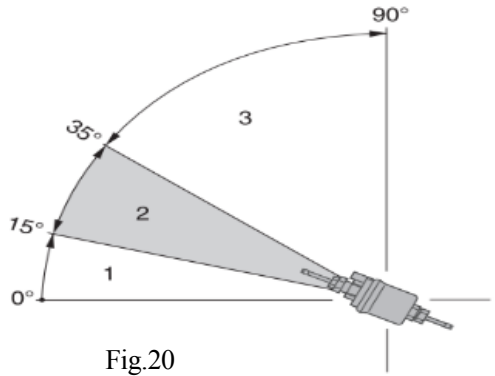

Fig.20

- 1-Installation position between 0° and 15° is not allowed.
- 2-Preferred installation position in range 15° and 35°
- 3-Installation position in range 35° and 90° is allowed.

Damper installation

Damper installation should be according to the practical situation. If the packing list doesn't include the damper then it should not be used temporarily.

Installation of Fuel Filter (only diesel)

A fuel filter shall be installed before the fuel inlet port. Please make sure that the fuel flow is correctly followed. Its position shall be in conformity with Fig. 21.

Fuel filter should be changed after 2 years, fuel pipe and clamps should also be changed.

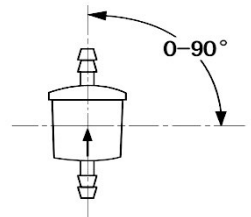

Fig.21

Note

Safety instructions for installing the fuel pump

Always mount the dosing pipe with the pressure side rising upwards-minimum incline 15°

Protect the dosing pump and filter from intolerable heat, do not mount near to the silencer and exhaust pipes.

Fuel criterion

Gasoline should meet the criterion DIN EN 228

Diesel should meet the criterion DIN EN 590

Note

The fuel brand should be used to meet the requirements of low temperature in winter and biofuels is not allowed.

Note

After refueling with winter or cold diesel, the fuel pipes and the metering pump must be filled with the new by letting the heater run for 15 min.

Possible suction and pressure height of the dosing pump

Pressure height from vehicle tank to dosing pump:

$a = \text{max.} 3000\text{mm}$

Intake height in pressure-less vehicle tank:

$b = \text{max.} 1000\text{mm}$ for diesel

$b = \text{max.} 500\text{mm}$ for petrol

Intake height in vehicle tanks with withdrawal by negative pressure (valve with 0.03bar in tank cap)

$b = \text{max.} 400\text{mm}$

Pressure height of the fuel pump to the heater:

$c = \text{max.} 2000\text{mm}$

Note

Check tank venting

Installation of Fuel Sucking Device

When fuel is sucked from the vehicle fuel tank or from an independent fuel tank, a sucking pipe shall be used. Attention shall be paid to that the openings on the fuel tank (or tank cover) for installation shall be size $\phi 25 \pm 0.2$, with trimmed brim and with good evenness around the opening. Good sealing is necessary for the base of the fuel sucking pipe. The bottom end of the fuel sucking pipe shall be 30mm-40mm from the bottom of fuel tank to suck enough fuel and at the same time to avoid sucking in impurities sediment on the bottom of fuel tank (Fig.23).

If fuel is sucked from the fuel pipe to the engine, the fuel pipe from the fuel tank to the fuel filter shall be disconnected and re-connected with the thicker pipes of the reducing T and the thinner pipe of the reducing T shall connect the fuel pump of the heater via oil pipe fitting and fuel pipe. Must ensure fuel extraction without any pressure and extract the fuel smoothly when the car is stopping. The angle for installation must in conformity with Fig.18, or normal work of the heater will be affected.

After installation, the vehicle engine shall be started and then turned off after one minute's work to eliminate air trapped in the fuel sucking pipe.

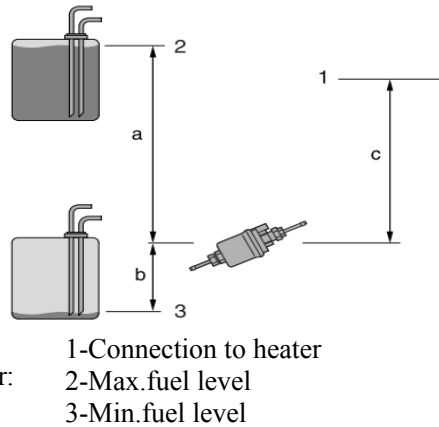

Fig.22

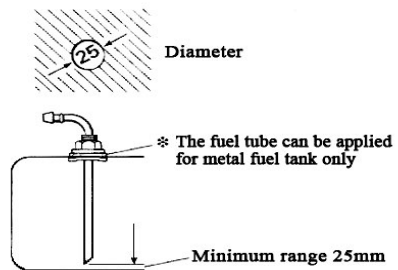

Fig. 23

4. Electrical system

Heater wiring

Note

Safety instructions for wiring the heater

The heater is to be connected up electrically according to the EMC directives. EMC can be affected if the heater is not connected up correctly. For this reason comply with the following instructions:

Ensure that the insulation of electrical cables is not damaged. Avoid: chafing, kinking, jamming or exposure to heat.

In waterproof connections, seal any connector chambers not in use with filler plugs to ensure they are dirt-proof and water-proof.

Electrical connections and ground connections must be free of corrosion and firmly connected.

Lubricate connections and ground connections outside the heater interior with contact grease.

Note

Comply with the following when wiring the heater and the control element:

Electrical leads, switchgear and controllers must be arranged in the vehicle so that they can function perfectly under normal operating conditions (e.g. heat exposure, moisture etc.).

The following cable cross sections are to be used between the battery and heater. This ensure that the max. Tolerate voltage loss in the cables does not exceed 0.5V for 12V or 1V or 24V rated voltage.

Cable cross sections for a cable length of (plus cable minus cable):

<5m = cable cross section 4mm²

5m~8m = cable cross section 6mm²

If the plus cable is to be connected to the fuse box (e.g. terminal 30), the vehicle cable from the battery to the fuse box must be included in rating the overall cable length and possibly re-dimensioned if necessary.

Insulate unused cable ends.

Installation for control switch

Remove the adjustment knob and show the screw hole, install the adjustment knob after fixing control switch with screw.

External temperature sensor (optional)

We can realize the function of the designated area temperature control. The default sensor is external temperature sensor after installing external temperature sensor.

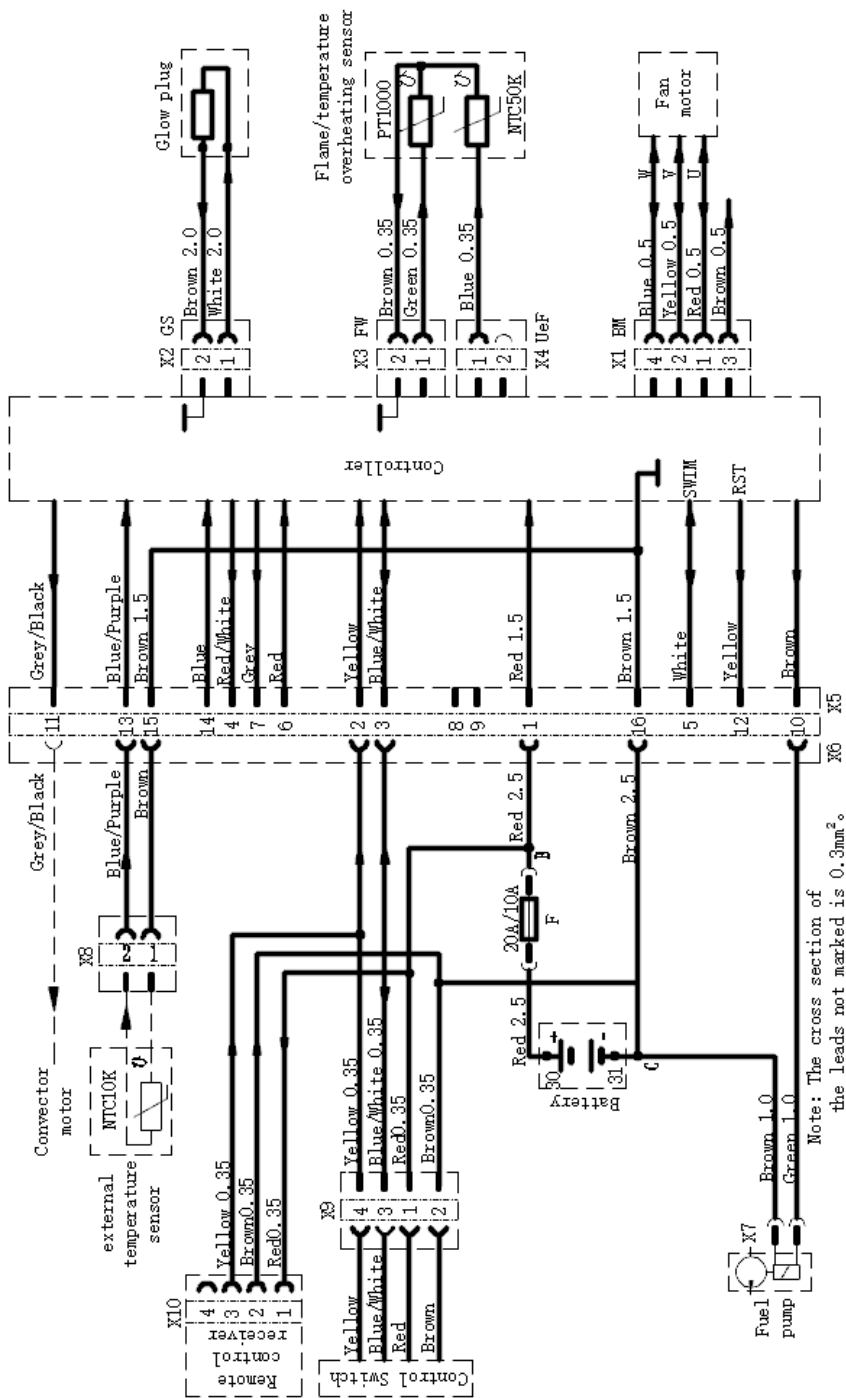

Note: The cross section of the leads not marked is 0.3mm².

Fig. 24

5. Operation and working condition

• Control Switches

The control switch is shown in Fig. 25.

It is used for the following operations:

- turning on or off of the heater;
- regulate the heating temperature or the heater power;
- eliminating locking of the heater due to trouble interrupt;
- converting working mode through the mode conversion button;

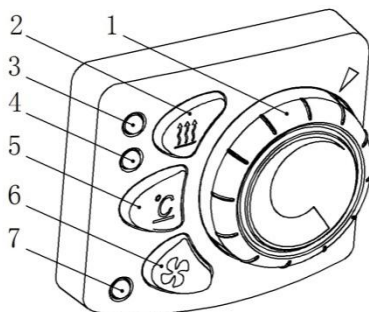

Fig.25

- 1-Control Knob
- 2- Heating(constant power)mode button
- 3-Heating(constant power)indication light
- 4-Air conditioner(constant temperature) indication light
- 5- Air conditioner(constant temperature) mode button
- 6- Ventilation mode button
- 7-Ventilation indicating light

•LCD switch (Optional device, see Fig.26)

Display set temperature

Set heat starting time

Set heat time

Display fault information

Eliminate fault code

Digital display power level



•GSM remote controller(Fig.27)

GSM remote controller is an extended function device of parking heaters which can be started and stopped through calling or sending message to the number of SIM card in the GSM remote controller by phones or cellphones. Control ways include voice and short message. It can start and power off heater immediately.



Fig.27

Operation methods for LCD switch and GSM controller (Both of the parts are optional) please see relevant instructions.

Operation of control switch

Heating (constant power) mode

Press air conditioner (constant temperature) mode button then the heating(constant power)indication light turns yellow, use the control knob adjust heater power.(adjustable continuously).

Air conditioner (constant temperature) mode

Press Air conditioner(constant temperature) mode button then Air conditioner(constant temperature) indication light turns red, use the control knob to set the control temperature of the heated area(adjustable continuously from 5°Cto 35°C).

Note

Push air conditioner (constant temperature) button or heating(constant power) button, then the indicator light of air conditioner (constant temperature) or heating(constant power) flash 0.3S, then lit, said controller has started work, enter the corresponding working mode. The heater comes to the start stage.

Ventilation mode

You can only enter the ventilation mode when you press the ventilation mode key to start the heater. Heater only circulating air without heating. Fan speed can be adjusted by control knob.

Heating (or air conditioner) working mode

Corresponding lights turn on by pressing heating (or air conditioner) button then glow plug switched on and the fan starts at a low speed.

Note

If there is too much residual heat in the heat exchanger from when the heater was last used, firstly only the fan starts up(cold blowing).

Once the residual heat has been cleared, the heater starts.

After approx.65 seconds the fuel supply starts and the fuel/air mixture in the combustion chamber ignites. Once the combined sensor (flame sensor)has detected the flame, the glow plug is switched off after 60 seconds. The heater is now in standard operation.

Convert working mode

Convert to the work mode by press the unlighted corresponding light.

Operation of running heater

Adjust the heating power and air temperature by rotating the switch.

During heating (constant power) mode, the room temperature or the temperature of the sucked in heating air is constantly measured.

During air temperature (constant temperature) mode, if the temperature is higher than the temperature selected on the control element, the heater starts to intermittent condition.

Intermittent condition.

The fan runs on for approx.3 minutes to cool down then restart again.

Switching off

Press the button which the corresponding indicator light is on.

Indicator light extinguished and fuel pump stop working after switching off the heater. The fan running and cooling down continuously about 3 minutes in the switch off process.

Control and safety devices

If the heater does not ignite within 90 seconds after starting the fuel pump, the start is repeated. If the heater still does not ignite after another 90 seconds of pumping fuel, the

heater is switched off, i.e. the fuel supply is off and the fan runs on for approx.3 minutes. If the flame goes off by itself during operation, the heater is restarted. If the heater does not ignite within 90 seconds after the fuel pump has started or ignites and goes off again within 15 minutes, the heater is switched off, i.e. the fuel supply is off and the fan runs on for approx.3 minutes. This status can be remedied by briefly switching off and on again. Do not repeat the switching off/on routine more than twice.

In the case of overheating, the combined sensor (flame sensor/overheating sensor) triggers, the fuel supply is interrupted and the heater switched off. Once the cause of the overheating has been switching off and on again.

If the lower or upper voltage limit is reached, the heater is switched off after 20 seconds.

The heater does not start up when the glow plug is defect or when the electric lead to the dosing pump is interrupted.

If the combined sensor (flame sensor/overheating sensor) is defect or the electric lead interrupted, the heater starts up and is then switched off again during the start phase.

The speed of the fan motor is monitored continuously. If the fan motor does not start up or if the speed deviates by more than 10%, the heater is switched off after 30 seconds.

When the heater is switched off, the glow plug is switched on for 40 seconds (after-glowing) while the fan runs on to clean off any combustion residues.

Emergency shutdown

If an emergency shutdown is necessary during operation, proceed as follows:

Switch the heater off with the control or

Pull the fuse out of

Disconnect the heater from the battery

Note

Do not switch the heater off and on again more than twice.

6. Troubleshooting

Circuit troubles may be caused by different reasons, such as corrosion of connectors, poor contact of connectors, wrong connection of wires, corrosion of wires or fuse, corrosion and looseness of battery poles, etc. Users need to check and prevent such troubles and offer good maintenance.

The reasons for the troubles to the heater can be indicated by the green LED on the control switch. In trouble status, indicator light will flash circularly, each circulation include 2 seconds extinguishing and a few 0.5 seconds times of slow flashes appear alternately. During the period between two long extinguishing, the times of slow flashes represent the types of troubles.

During use, the heater may become unable to start normally or die out after start. Such troubles may lead to locking state. In such case, you can press the button which is lighting on then work indicator goes out. Turn off the heater and keep it in such state for at least 5 seconds. Then restart the heater.

When the following troubles occur, users can take measures to solve:

Failure to turn on the heater and the indicator light is not illuminating; the reason is open circuit of fuse or wrong connection of wires.

The heater runs idly and no start process occurs after the heater is powered on, this indicates that the temperature of air inlet (or the ambient temperature around the external

Others need attention

The ambient temperature shall be in the range of $-40^{\circ}\text{C}\sim 85^{\circ}\text{C}$ for transport and storage of the heater to avoid any damage to its

Only authorized customer service stations are allowed to provide repair and installation for the heater. It is prohibited to make repair by yourself or use non-manufacturer's parts or components so as to avoid danger.

The manufacturer shall not be held responsible for any damage to the heater if the heater is opened without authorization or such damage is caused due to installation or operation with violation against the regulations.

When fill fuel for the heater, you have to turn off the power first. To do this, just turn the control switch anticlockwise to position "0"

If electric welding is performed to the vehicle, please detach the positive wire of power supply of the heater from the battery and connect it to earth to protect the controller from any damage.

