

Air parking heater

Technical description, installation, operation
and maintenance instructions.

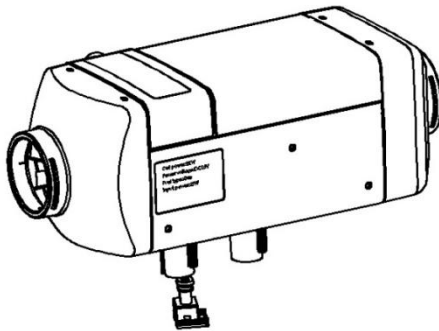

Product type	Order No.
Diesel 12V	4W2002 12C21
Diesel 24V	4W2002 24C21

Air heater for operating independently of the engine.

Plateau version

Preface

Thank you for choosing 2KW air parking heater.

This instruction book describes the structures, working principles, installation and operation of the parking heater. For correct use of the heater, please read this instruction book carefully before installation and use. The instruction book shall be saved in a convenient place for later reference.

Attention:

- This instruction book is subject to revision without notice, but the instruction book is in conformity to the purchased product.
- Our effort is to explain all questions the users may have through this instruction book. If you have any doubts or find anything incorrect in this instruction book, please contact our company directly.
- At first unpacking, please check the heater and its accessories against the packing list. Please contact the dealer immediately if any problem is found.
- If any trouble arises during application, please contact the Department of Marketing of our company or other customer service stations authorized by our company. We shall do our best to provide service to you.

Note:

Comply with the operational manual for installation and use to ensure that the heaters can work for a long time.

1 Introduction

The main equipment of Model 2KW air parking heater (hereinafter referred to as the heater) is a small fuel furnace controlled by a single-chip micro-processor. Its furnace body (the heat exchanger) is located in the hood-shape case, which serves as independent air passage. Cold air is sucked into the air passage by the heat supplying fan and blown out when it becomes hot, so as to form another heating system that is

independent to the original heating system of the vehicles. In such a way, heat can be supplied by the heater to driver's cab and passengers' compartment no matter the engine is working or not working. The schematic diagram is shown in Fig. 1.

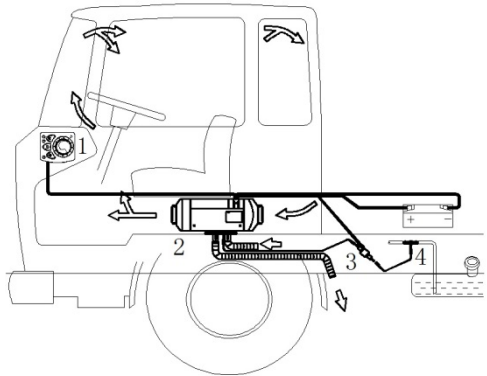

Fig. 1
1-Control switch 2- Heater

The heater is fully automatically controlled. It features in compact structure, easy installation, energy-saving, environmental protection, safety and reliability, easy maintenance, etc.

2 Main Technical Specifications

Please refer to Table 1 for main technical specifications.

Table 1

Heat Power (W)	2000	
Fuel	Gasoline	Diesel
Rated Voltage	12V	12V/24V
Fuel Consumption	0.14~0.27	0.12~0.24
Rated Power Consumption (W)	14~29	
Working (Environment)	-40°C~+20°C	
Working height above sea level	≤5000m	
Weight of Main Heater (kg)	2.6	
Dimensions (mm)	Length323±2 width 120±1 height121±1	
Mobile phone control (optional)	No limitation (GSM network)	

3 Structures and Working Principles

The structures of the main heater are shown in Fig. 2

3.1 Heater

Fig.3 is the diagram for structure of the heater.

Heat exchanger 1 is the combustion furnace body, made of die-casting aluminum, with radiating fins around and at the rear end. Combustion pipe 3 is installed in the inner cavity. The front of the combustion pipe insert the combustor 4, Fuel comes to the combustor core through the fuel pipe 13 and is ignited by the glow plug 14 after atomization. The flame enters the gap between the inner walls of the furnace body through the rear-end guide pipe of the combustion pipe, The exhaust is discharged through exhaust pipe vent 15.

The fresh air for supporting combustion of the furnace comes from the supporting air inlet port 12 and is sent to the combustion pipe by the combustion supporting air blades 6 of the fan motor.

Burner is quick-wear part which should be replaced after every 800 hours

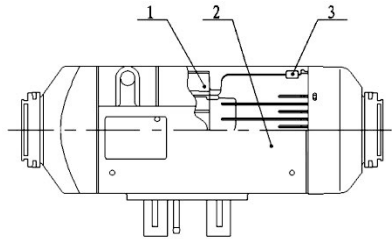

Fig. 2
1-Heater 2-Hood-shape case
3-Insulating mat

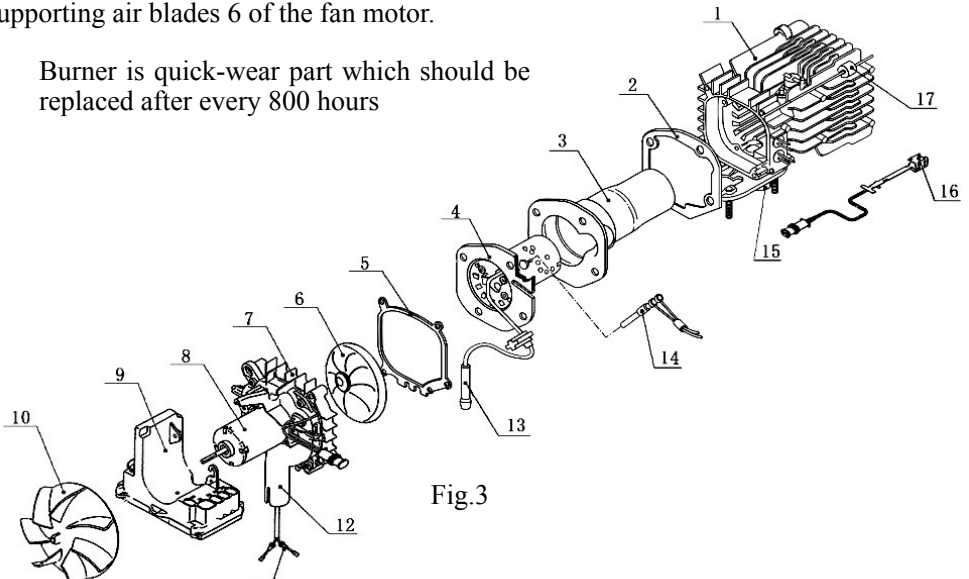
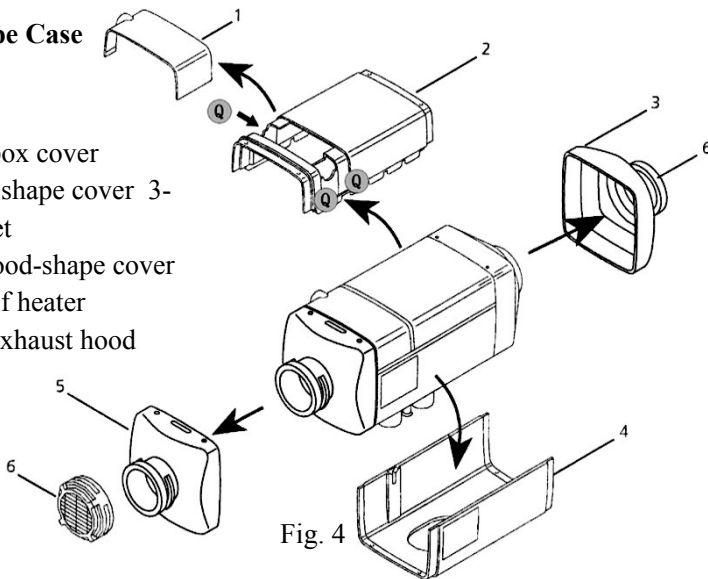

Fig.3

- 1-Heat exchanger 2-Gasket 3-Combustion pipe 4-Burner 5-Gasket
6-Combustion supporting fan blades 7-Bracket for fan motor 8-Fan motor 9-
Controller 10-Blade wheel of heating fan 11-Fuel pump leading wire
12-Inlet of combustion supporting air 13-Fuel inlet pipe 14-Glow plug
15-Exhaust pipe vent 16-Overhear sensor 17-Insulating mat

3.2 Hood-Shape Case

- 1-Junction box cover
- 2-Top hood-shape cover
- 3- Hot air outlet
- 4-Bottom hood-shape cover
- 5-Air inlet of heater
- 6-Air inlet/exhaust hood



The structure of the hood-shape case is shown in Fig. 4. It consists of the top cover 2 (The junction box cover 1 can be fixed on 2), bottom cover 4, air inlet hood 6, air inlet of heater 5 and hot air outlet 3. They form an air heating passage. Blade wheel of heating fan (Fig.3-10) on the fan motor (the same for supporting combustion fan) sucks in cold air from the air inlet. The air is heated by the heat exchanger and sent out from the hot air outlet.

3.3 Controller

The controller (Fig. 3-9) is at the front of the heater and the back of the blade wheel of heating fan. This controller main including collect the circuit and exam the temperature circuit of the signal of a single-chip、drive circuit、frequency、rotational speed、voltage. Have the function of heating process automation、system surveillance automation、breakdown handling automation.

3.3.1 Control of Working Procedures

Adjustment and control on operational status are performed during the whole working cycle (start-operation-stop) of heater in terms of the rotation speed of fan motor, the frequencies of fuel pump, on-off of glow plug, to given time sequence and in consideration of the preset value and measured value of the temperature of the temperature control point, rotation speed of fan motor feedback signal、frequency of fuel pump, surface temperature of the heat exchanger and other random parameters.

3.3.2 Locking Due to Troubles

When the heater cannot be ignited normally, or cannot sustain normal combustion after ignition, or broken circuit or short-circuit occurs to the glow plug, fan motor, fuel pump, or various sensors and components, or in case of overheating or

excessive temperature of heat exchanger, abnormal of power voltage and speed of fan motor when heater operation, the heater will turn off and enter into locked status (not working of glow plug, fuel pump and fan motor, LED light flashing on control switch) for protection.

3.3.3 Display of Troubles

For convenience of maintenance and repair, troubles of the heater can be displayed by the corresponding indicators of the control switch.

In trouble status, indicator light will flash circularly, each cycle consists of a long extinguishing (2 seconds) and several slow flashes (interval of about 0.5 seconds). During the period between two long extinguishing, the times of slow flashes represent the types of troubles, as shown in Table 2.

Table 2

Times of flashes of LED	Cause of trouble
1	Failure of second start
2	Termination of the third time of combustion
3	Power voltage out of specified range
4	Furnace temperature over high during self-check period
6	Broken circuit or short-circuit of temperature sensor
7	Broken circuit or short-circuit of fuel pump
8	Broken circuit, short-circuit, or rotation clogging of fan motor
9	Broken circuit or short-circuit of glow plug
10	Ambient temperature over high before starting or furnace body temperature over high during heating process
11	Broken circuit or short-circuit of overheating sensor
12	Broken circuit or short-circuit of control switch
13	Maintenance reminder: More than 800 hours of work time
14	Failure of controller

12V Heater operating voltage range:
10.5V~16V

24V Heater operating voltage range:
21V~32V

3.3.4 Circuit Interfaces

The following circuit interfaces can be found on the controller case:

Socket X1 for fan motor,

Socket X2 for glow plug,

Socket X3 for overheating sensor,

Socket X4 for the leads to fuel pump

Socket X6 for the main wire bundle.

Please refer to Fig. 5 for their locations.

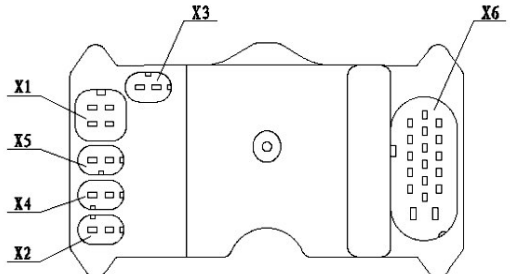

Fig.5

The connection parts are designed with such structures that wrong connection is made impossible.

3.4 Sensors and Safety Protection

3.4.1 Overheating Sensor

The overheating sensor (Fig.3-16) is installed on the back outer wall of the heat exchanger. If the temperature here becomes higher than upper limit , the fuel pump circuit will be cut off by the controller and supply of fuel is stopped and then the heater is turned off for purpose of overheating protection.

3.4.2 Temperature Sensor

The inside temperature sensor(in the controller) is installed on the air inlet of heater, it measures the air temperature at the air inlet ,according to the temperature change the working state of the furnace and adjust the output of the thermal power.

The outside temperature sensor is optional part which require extra configuration and can be put those heating places you want. Same working principle as inside temperature sensor.

3.5 Control Switches

The control switch is shown in Fig. 6. It is used for the following operations:

- turning on or off of the heater;
- regulate the heating temperature or the heater power;
- eliminating locking of the heater due to trouble interrupt;
- converting working mode through the mode conversion button;

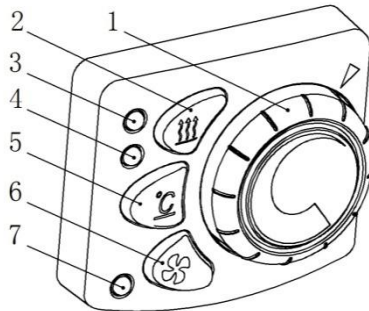

1-Control Knob Fig.6

- 2- Heating (constant power) mode button
- 3-Heating (constant power) indication light
- 4-Air conditioner (constant temperature) indication light
- 5- Air conditioner (constant temperature) mode button
- 6- Ventilation mode button 7-Ventilation indicating light

3.6 LCD control switch (see Fig.7)

- Display set temperature
- Set heat starting time
- Set heat time
- Display fault information
- Eliminate fault code
- Digital display power level



3.7 GSM remote controller (Optional device, see Fig.8)

GSM remote controller is an extended function device of parking heaters which can be started and stopped through calling or sending message to the number of SIM card in the GSM remote controller by phones or cellphones. Control ways include voice and short message. It can start and power off heater immediately.



Fig.8

Operation methods the GSM controller (Which is optional) please see relevant instructions.

3.8 Power Supply

Heater power leads (positive and negative line) must be connected to the 12V/24V batteries directly. Battery more than 2 years which lack of electric frequently should be changed a new one in order to ensure normal use of the heater.

3.9 Fuel Supply

The fuel for the heater can be from the fuel tank in the car or from optional 5L independent fuel tank. The fuel pump is used for transmission of fuel and regulation of supply quantity of fuel.

3.10 Fuel standard

Gasoline should accord with standard DIN EN288

Diesel should accord with standard DIN EN590

Note: Fuel brand which used should meet the requirements of low temperature in winter. Biofuel is forbidden!

4 Installations

Only special-purpose parts can be used for installation of the heater. Fig. 9 is the diagram for installation. The positions and ways of fixing of various parts may vary from one automobile model to another, but the general principles must be followed in conformity with the requirements of this chapter. Otherwise the heater may not work normally or safety problems may occur.

- A Connect with battery
- B Connect with external temperature sensor
- C Connect with fuel tank
- D Connect with heater
- E Connect engine
- 1- Control switch
- 2- Fuse
- 3- Heater
- 4- Gasket
- 5- Air inlet pipe
- 6- Fuel pipe
- 7- Air filter (optional)
- 8- Exhaust pipe
- 9- Tank (optional)
- 10- Tubing joint (optional)
- 12- Filter 13- Fuel pump

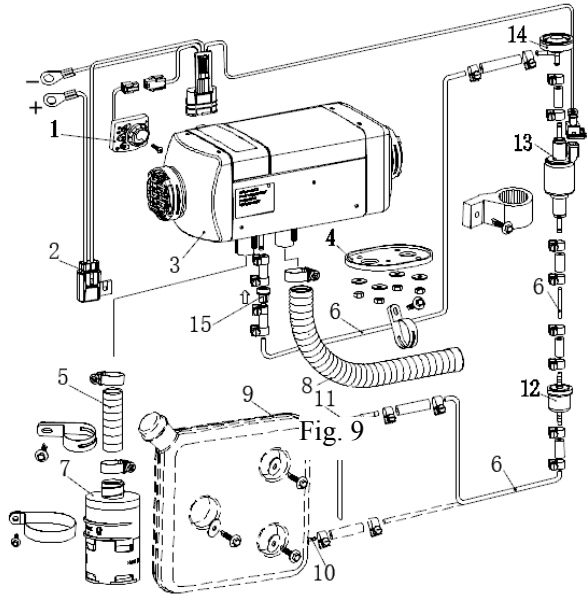

- 4.1
 - 4.1.1 It is not allowed to use substances such as flammable gas or flammable dust.
 - 4.1.2 It is not allowed to use the heater in closed space (such as garage or maintenance workshop without air ventilation) to avoid danger of poisoning due to exhaust from burning.

Attention: Under either of the above circumstances, it is not allowed to use the heater even at the stand-by state.

- 4.1.3 It is not allowed to install and use the heater in bedrooms.
- 4.1.4 If the heater is installed in special-purpose vehicles (such as vehicles for dangerous goods), special rules must be followed in installing the heater.
- 4.1.5 Never place fuel tank, compression tank, fire extinguisher, clothes, paper, etc. near the heater or opposite to the hot air vent.

4.2 Installation of the Main Heater

4.2.1 The main heater can be installed inside the vehicle or outside the vehicle. But when it is installed outside the vehicle a shield which can prevent the damage (splash of stones) of external force (supplied by retailers). The heater can't be soaked in

the water or in the rain for a long time(heater should be shut off).The heater should be operated after it is completely dried if the heater is corroded by rain and water.

4.2.2 For convenience of heating air flow and installation, maintenance of the main heater, enough space must be provided for installation. Please refer to the scope of double dot line for the space for installation, as shown in Fig. 10.

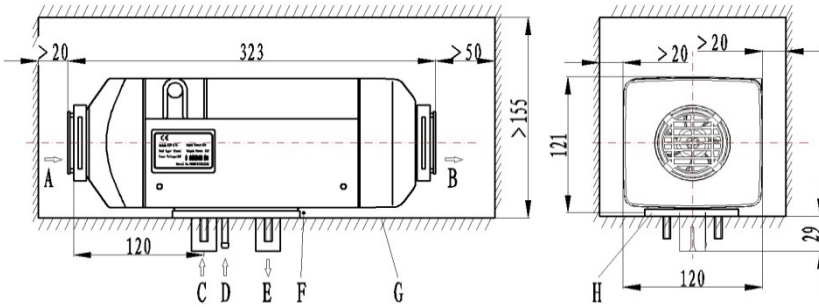

A-Inlet of heating air B-Outlet of heated air C-Inlet of combustion air
 D- Fuel inlet E-Exhaust outlet F- Non-interference area
 G-Installation surface H-Gasket

Fig. 10

Please make sure that there are not any interference objects in the gap between the bottom surface of the main heater and the installation surface of the vehicle (Fig. 8-F).

4.2.3 Good sealing is necessary between the main heater and the installation surface on the vehicle. A special gasket (as shown in Fig. 10) supplied by the manufacturer must inserted in between during installation. The installation surface must be smooth and steady enough. Its parts at the installation bases of the main heater shall have unevenness of less than 1mm. After drilling installation holes, evenness must be improved according to this requirement. At installation, please rotate the four M6 nuts, which provided by the manufacturer should be tighten. The torque for tightening shall be 6Nm+1Nm.

Please refer to Fig. 11 for positions of installation holes.

4.2.4 If the sickness of the installation panel<1.5mm a mounting plate may need. Between mounting plate and the car body must also be sealed (use glass glue(Fig.12)).

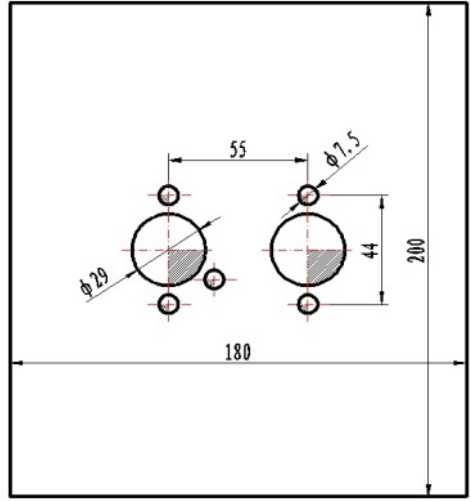
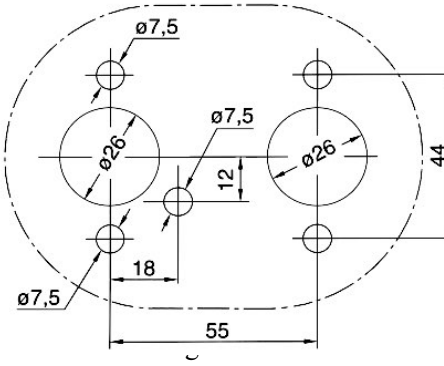

Attention: For a new gasket must be used to replace the old one.

4.2.5 Direction for installation of the heater is shown in Fig. 13. Attention must be paid to that the inclination angle shall not exceed the limit, or normal operation will be affected.

4.2.6 After installation of the main heater, please check and make sure that there is not any contact or friction between the blade wheel of fan and other nearby parts to avoid unsmooth operation

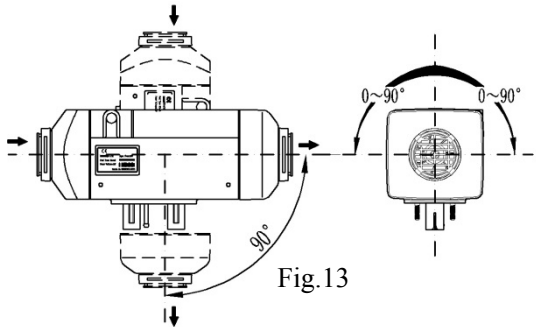

Fig.13

4.3 Installation of Air Heating System

4.3.1 The independent outer circulation or inner circulation mode of heater can be recommended. If the air heating system of the heater have to be connected with the air duct of the vehicle, in order to ensure the air duct unobstructed the connection way should be analyzed by the professionals.

4.3.2 When an external heating air pipe is attached to the heater, the pipe diameter shall not be smaller than 60mm. Its material shall be capable to resist temperature of 130°C.

4.3.3 The maximum pressure drop between the air inlet side and air outlet side of the air heating system shall not be greater than 0.15kPa.

4.3.4 The hot air from the heating system shall not erupt onto such parts that are unable to resist heat. In case of passenger vehicles, measures shall be taken to avoid

blocking of the hot air vent by passengers. A self-provided protective net can be installed if necessary.

4.3.5 For heater working in external circulation mode, the position of air inlet port shall be proper to guaranteed that under normal operation no splash of water can enter. No water can be sucked into the heater and no exhaust from the engine can be sucked in.

4.3.6 For heater working in internal circulation, measures shall be taken to avoid re-entering of the supplied hot air into the air inlet port (as shown in Fig. 14). If no air inlet pipe is attached in this mode, an air inlet hood with grids (Fig3. 4-6) must be installed at the air inlet port of the main heater. The inlet air shall be drawn from the cold area of the compartment, such as under the seats or berths.

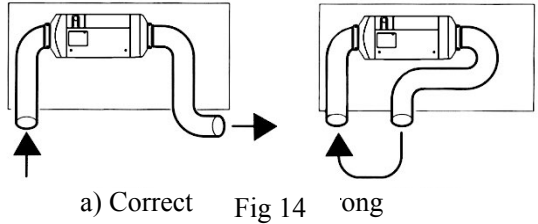

4.3.7 The optional air duct fittings

Users can choose the air duct fittings according to the situation. Please refer to Fig

No	Name	Specification
A	Grill	φ90
B	Diameter changes joint	φ60
		φ90/60
		φ56/60
C	Elbow	φ60/90°
D	Clamp	φ50~70
E	Ducting	φ60/φ64
F	Connector	φ60-φ60
G	Reducing T	φ60

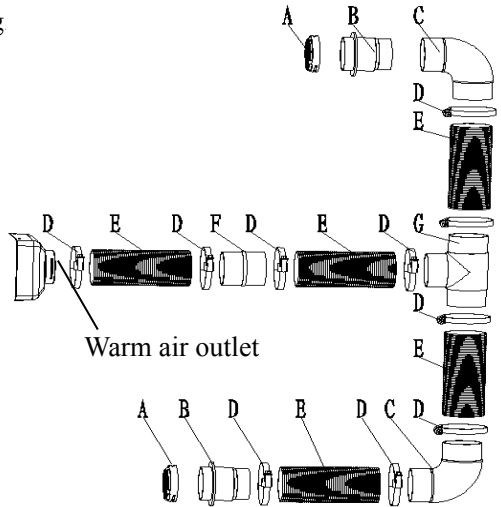
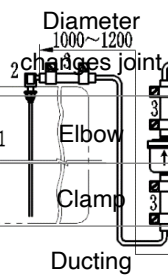

Fig. 15

No	Name	Specification
A	Connector	$\Phi 60$
B	Reducing fit	$\Phi 90/60$
C	Elbow	$\Phi 60/90^\circ$
D	Clamp	$\Phi 50 \sim 70$
E	Ducting	$\Phi 60/\Phi 63$
F	Connector	$\Phi 60/\Phi 60$
G	Reducing fit	$\Phi 60$

4.4 Installation of Fuel Supply System
 The fuel supply system for the heater is as shown in Fig. 16.

Fuel pipe surface



- 1-Fuel tank
- 2-Fuel extractor
- 3-Fuel pipe connector
- 4-Filter
- 5-Fuel pipe
- 6-Fuel pump
- 7-Damper
- 8- Non-return valve

4.4.1 The fuel pump shall be fixed in automobile with a fuel pump clamp with protective rubber cover. The outlet of the fuel pump shall tilt upwards. The tilt angle can be reduced from the range of 15~35° (as shown in Fig. 17). When conditions permit, the fuel pipe between the fuel pump and the heater shall go up gradually.

4.4.2 Damper installation should be according to the practical situation. If the packing list doesn't include the damper then it is should not be used temporarily.

4.4.3 Difference in elevation between the level of fuel and the fuel pump as well as the difference in elevation between the fuel pump and the fuel inlet of the heater can produce pressure (or suction) in the fuel pipeline(See Fig.17).So, these dimensions shall conform to the requirements as follows:

$a \leq 3m$ $b \leq 0.5m$ (Avoid of negative pressure may be produced in sealed fuel tank.
 In such case, $b \leq 0.15m$) $c \leq 2m$.

- 1-Fuel pump
- 2-Max.fuel level
- 3-Min.fuel level
- 4-Fuel inlet level

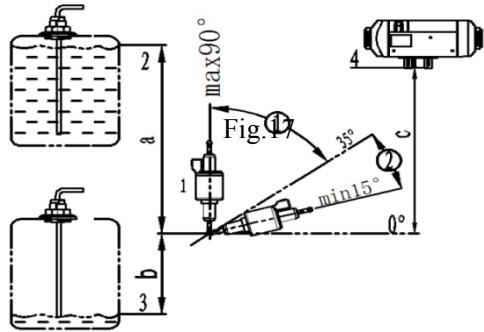

Note: Allowable installation angle

1. Please check the vent on the fuel tank when doing installation.

2. Fuel pipe after clipping (must use blade, Scissors or pliers are forbidden) should ensure not affect fuel flow amount.

4.4.4 Installation of Fuel Filter

A fuel filter shall be installed before the fuel inlet port. Please make sure that the fuel flow is correctly followed. Its position shall be in conformity with Fig. 18.

Fuel filter should be changed after 2 years, fuel pipe joints and clamps should also be changed.

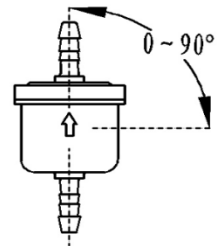

Fig.18

4.4.5 Installation of Fuel Pipe

4.4.5.1 Only the flexible nylon pipe, which has good light-resistance and thermal stability, supplied with the heater can be used as the fuel pipe. The inner diameter of the pipe is $\Phi 2\text{mm}$.

4.4.5.2 The place for installation of fuel pipe shall be resistant against flying stones and shall be away from any heat emitting parts of the vehicle. Protective device can be installed if necessary.

4.4.5.3 The fuel pipe from the fuel pump to the main heater shall be in any directions other than downward direction. The fuel pipe shall be tied in some proper location to make it fixed. The distance between two ties shall be less than 50cm.

4.4.5.4 The fuel pipe fittings supplied with the heater shall be used for connections between fuel pipe and fuel pump, fuel pipe and heater, fuel pipe and sucking pipe of fuel tank and fuel pipe and reducing T. The fuel pipe shall ties with fuel pipe clamps. Bubbles shall be eliminated from the connecting places (Fig. 19).

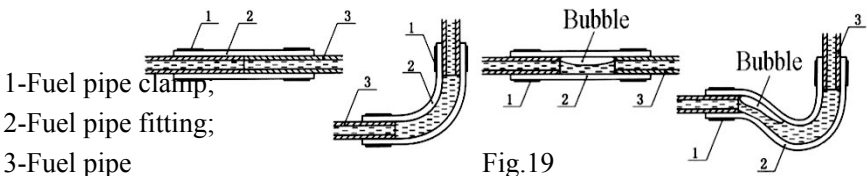

Fig.19

b) Wrong

4.4.6 Installation of Fuel Sucking Device (Fig.20)

4.4.6.1 When fuel is sucked from the

vehicle fuel tank or from an independent fuel tank, a sucking pipe shall be used. Attention shall be paid to that the openings on the fuel tank (or tank cover) for installation shall be size $\phi 25 \pm 0.2$, with trimmed brim and with good evenness around the opening. Good sealing is necessary for the base of the fuel sucking pipe. The bottom end of the fuel sucking pipe shall be 30mm-40mm from the bottom of fuel tank to suck enough fuel and at the same time to avoid sucking in impurities sediment on the bottom of fuel tank.

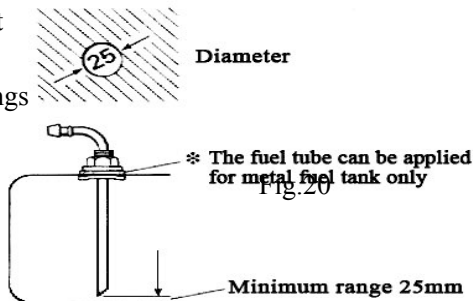

4.4.6.2 If fuel is sucked from the fuel pipe to the engine, the fuel pipe from the fuel tank to the fuel filter shall be disconnected and re-connected with the thicker pipes of the reducing T and the thinner pipe of the reducing T shall connect the fuel pump of the heater via oil pipe fitting and fuel pipe. Must ensure fuel extraction without any pressure and extract the fuel smoothly when the car is stopping. The angle for installation must in conformity with Fig. 21, or normal work of the heater will be affected.

After installation, the vehicle engine shall be started and then turned off after one minute's work to eliminate air trapped in the fuel sucking pipe.

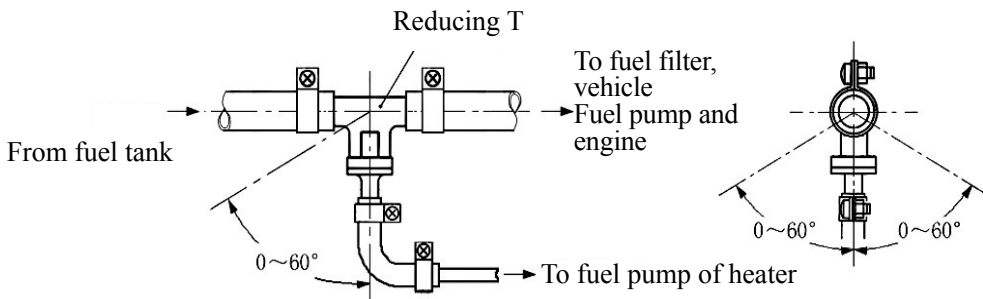

Fig.21

4.5 Installation of Electrical System

4.5.1 The wiring diagram for the heater is shown in Fig. 22. The wires of the main heater for connection to outside circuits have been made into wire bundles. They can be laid according to the positions of various components and shall be fixed in some proper locations. The distance between two fixing points shall not exceed 30cm. Attention: Any exposed wire bundle out of the vehicle body or out of the wiring groove must be protected by corrugated pipe.

4.5.2 Connection of the main wire bundle with the heater: Use a blunt tool to pry the places marked "○Q" of Fig.4 gently to remove the junction box cover (Fig. 4-1). Connect the 18-wire connector X6 of the wire bundle to the controller socket. The wire bundle can come out from either the right

side or the left side of the heater. Then replace the junction box cover. Make sure to have good sealing between the junction box cover and upper cover and between the junction cover box and the wire bundle sealing mat to avoid any thermal malfunction due to leak of air from the hood-shape case.

4.5.3 Insert sheet fuse into fuse holder F and replace the upper cover tightly. Use screws to fix it in a proper location in the vehicle.

4.5.4 Connect the 2.5mm² red wire and the 2.5 brown wire in the wire bundle to the hole terminals with springs and therefore connect to the “+” and “-” terminals of the vehicle battery.

Note: the above parts even if not in use, should also be inserted the terminal socket for future upgrade and prevent short circuit in the meanwhile.

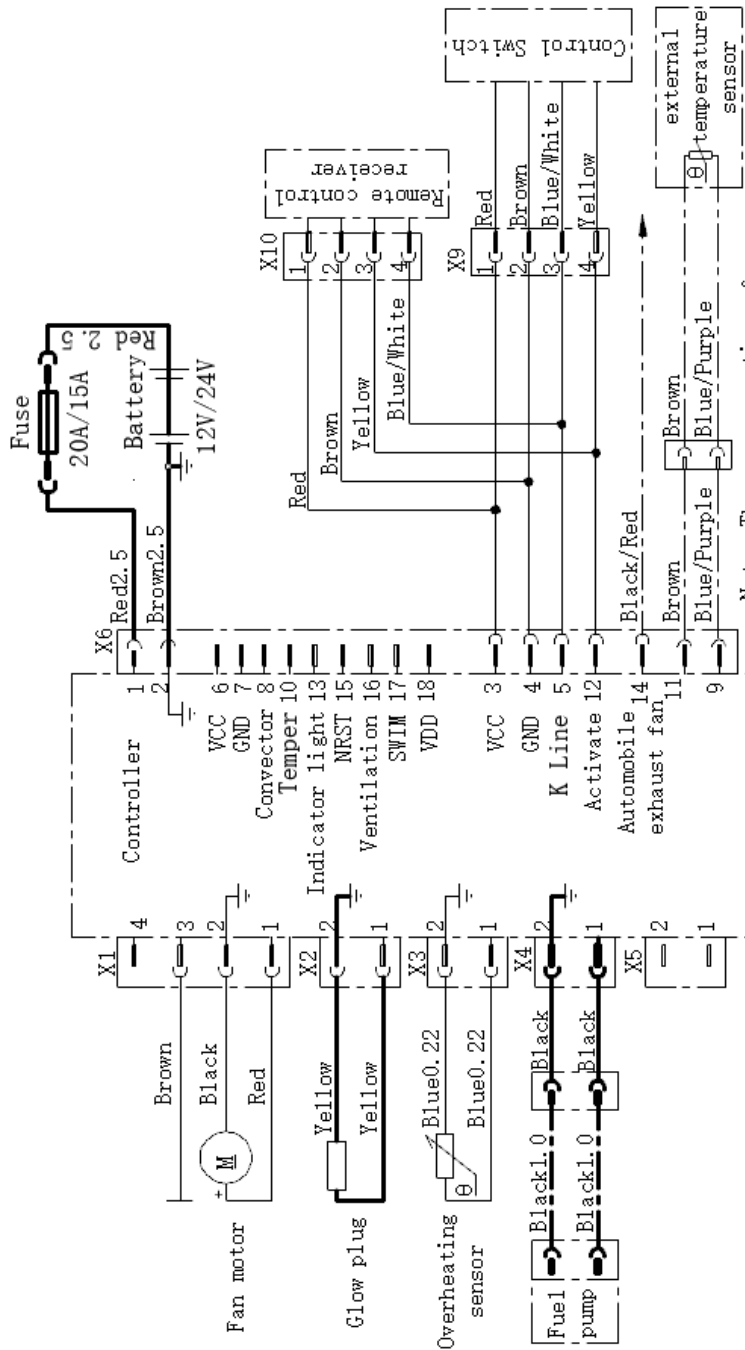

Note: The cross section of

4.5.5 Straighten the fuel pump leads (two 0.6mm² black wires and not distinguish positive and negative) with their protective pipes, which is made a coil inside the combustion supporting air inlet port , and put them through the opening on the wall of the air inlet pipe. Connect the insert of fuel pump connector with fuel pump(Insert the right position).Cutting fuel pump leads is forbidden.

4.5.6 Use four self-tapping screws to fix the control switch in a position for convenient operation and the arrangement shall make easy observation on the indicator on the case, so as to identify the working conditions (operation/stop) of the heater easily. The plugs on the leads from the control switch shall be connected to the main wire bundle and make self-locking mechanism. Note to remove the knob firstly, then install the knob after fixing the screw.

4.5.7 The surplus wires in the wire bundle at the moment are wires for fault diagnosis、information adjustment and function expansion. They shall be kept in good condition. Their ends shall be wrapped with electrician's insulating tape to avoid short-circuit or earthing.

4.6 Installation of combustion supporting air sucking pipe and exhaust discharge pipe

4.6.1 The combustion supporting air must be sucked in from external fresh air outside the vehicle. The exhaust from combustion must be discharged into the air through exhaust pipe. Measures must be taken to avoid the exhaust from re-entering the vehicle.

The pipes go through the outer wall or holes on the bottom of vehicle. Measures must be taken to prevent entering of splash water. The pipes must be protected and can resist shock permanently.

4.6.2 Only the air inlet pipe and exhaust pipe provided with the heater can be used. The air inlet pipe is a corrugated pipe made of a aluminum pipe that it's surface is covered by plastic and paper; The exhaust pipe is corrugated stainless steel pipe. Please identify air inlet pipe and exhaust pipe and do not make mistake at installation. To connect them with the heater, please use the supplied clamps to fix them tightly on the combustion supporting air inlet and exhaust pipe vent respectively. The protective hood on the vents of the air inlet pipe and exhaust pipe must be kept in good condition. Do not damage them or remove them.

In order to meet the dust environment, an optional air filter is a good choice(Fig.23). A length of air filter can be cut in order to meet different thickness of air inlet pipes.

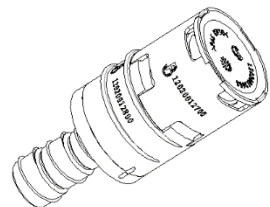

Fig.23

4.6.3 Both the air inlet pipe and exhaust pipe shall come outwards and downwards from the heater (Fig. 24), otherwise a $\Phi 4\text{mm}$ hole shall be prepared at the bottom of the pipe for discharge of condensation water.

If the pipe need curve, the radius cannot be smaller than 50mm. Also, the sum of all curve angles for each pipe shall not exceed 270° .

4.6.4 The openings of the pipes shall not be opposite to the direction of the running vehicle. (Fig. 25)

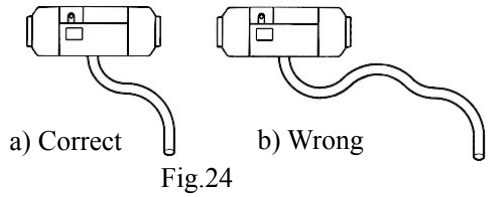

Fig.24

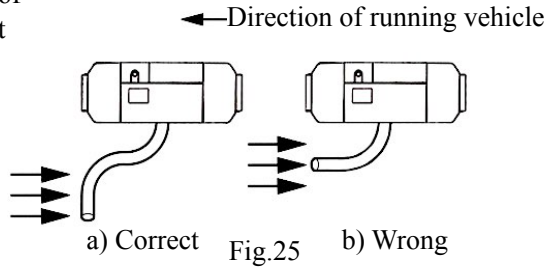

Fig.25

4.6.5 Arrangement of the pipes shall protect the pipe openings from blocking by slurry, rain and snow or other dirt. (Fig. 26)

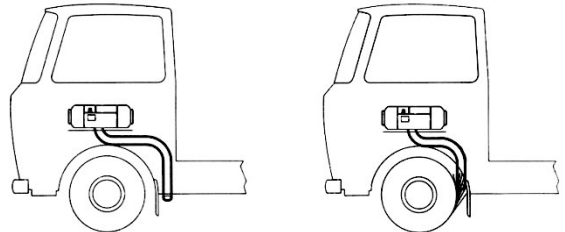

Fig.26

4.6.6 When the heat is working, the exhaust pipe is at high temperature. In installation, make sure to install it in far distance from plastic parts or other objects with poor thermal resistance of the vehicle body. The exhaust pipe shall be properly fixed. The exhaust vent shall be downwards, perpendicular to road surface with an angle of $90^\circ \pm 10^\circ$. To ensure such an angle, the fixing clamp for the exhaust pipe shall be within 150mm from the pipe end. (Fig. 27)

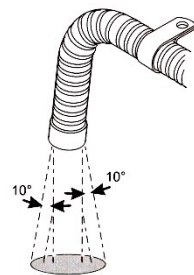

Fig.27

Warning: Violation against the above requirements may cause fire.

Any consequences caused by not installing according our requirement we don't afford any responsibility.

4.6.7 If the section of the exhaust pipe inside the vehicle may be touched by passenger, a protective cover has to be installed to prevent human contact and scald.

5 Methods of Operation

5.1 The heater control with three ways.

- (1) Use the control switch(normal configuration).
- (2) Use LCD control switch(optional choice).
- (3) Use GSM mobile phone controller(optional choice).

5.2 Use the control switch

5.2.1 Power on

Push air conditioner (constant temperature) button or heating(constant power) button, then the indicator light of air conditioner (constant temperature) or heating(constant power) flash 0.3S, then lit, said controller has started work, enter the corresponding working mode. The heater comes to the start stage. The controller will run heating program according to the temperature control target set by the control knob. In the start stage, the time delay from switch-on to fuel supply to the fuel pump is 65 seconds.

5.2.2 Power control

After the combustor is ignited, if you want to regulate the heating temperature or the heater power, you can turn the control knob according to the arc mark around the control switch.

5.2.2.1 Air conditioner(constant temperature) mode

The air conditioner(constant temperature) mode indicating light is illuminated after pressing air conditioner (constant temperature)button. If you want to adjust the heating temperature(adjustable continuously from 5°Cto 35°C),press the curve sign on the control switch and turn the control knob.

5.2.2.2 Constant power mode

The heating(constant power) mode indicating light is illuminated after pressing heating (constant power)button. If you want to adjust the heating power(adjustable continuously between 1KW and 2KW), press the curve sign on the control switch and turn the control knob.

5.2.3 Ventilation mode

You can only enter the ventilation mode when you press the ventilation mode key to start the heater. The ventilation indicating light turns green after pressing ventilation button. Heater can only circulating air without any heating. The wind capacity can be continuously regulated with the control knob.

5.2.4 Shutdown

If you want to turn off the heater manually, press the button which is lighting on then work indicator goes out. If the fuel pump is at work before the heater is turned off, the pump will shut down immediately. But the fan will continue to run for 180 seconds.

5.2.5 Use any other way shut off the heater (cut off the power) directly is not allowable.

6 Treatment of Usual Troubles

6.1 During use, the heater may become unable to start normally or die out after start. Such troubles may lead to locking state. In such case, you can press the button which is lighting on then work indicator goes out. Turn off the heater and keep it in such state for at least 5 seconds. Then, restart the heater.

6.2 Circuit troubles may be caused by different reasons, such as corrosion of connectors, poor contact of connectors, wrong connection of wires, corrosion of wires or fuse, corrosion and looseness of battery poles, etc. Users need to check and prevent such troubles and offer good maintenance.

6.3 The reasons for the troubles to the heater can be indicated by the green LED on the control switch (see Section 3.3.3 for details). When the following troubles occur, users can take measures to solve:

(a) Failure to turn on the heater and the indicator light is not illuminating, the reason is open circuit of fuse or wrong connection of wires.

(b) The heater runs idly and no start process occurs after the heater is powered on, this indicates that the temperature of air inlet (or the ambient temperature around the external temperature sensor) is higher than the set heating temperature, or called hot start. In such case, you need to turn the control switch knob clockwise to have a higher set temperature.

(c) When the LED flashes once, troubleshooting can be solved by the methods list in table 4.

Table 4

Times of flashes of LED	Troubleshooting methods
1	a Check whether the fuel pipe is blocked or whether the fuel in the tank is sufficient. b Check whether the exhaust pipe is blocked. c Check whether fuel mass is appropriate.
2	a Ditto b Ditto c Ditto d Replace the fuel pump
3	a Abnormal voltage, if the voltage is very low, then battery should be charged.
4	a Use ventilation mode cooling if temperature over high. b Or replace controller.
6	a Replace controller
7	a Check whether fuel pump lead connection is reliable. b Replace fuel pump. c Replace controller.
8	a Check whether the fan wheel have any scrape. b Replace fan motor assembly. c Replace controller.
9	a Clean the carbon deposition of glow plug. b Replace glow plug. c Replace controller.
10	a Whether air inlet and outlet are blocked. b Whether junction box cover tightly. c Whether inlet air and exhaust air short circuit.
11	a Check overheat sensor (normal temperature resistance is about 1kΩ). b Replace overheat sensor.
12	a Check connection of control switch. b Replace control switch.
13	a Need to clean up the carbon deposition and maintenance work.

14	a Replace controller
----	----------------------

7 Precautions

7.1 After the heater is installed, in order to remove air trapped in the fuel supply system thoroughly and fill the fuel route with fuel only we Specially designed for oil pump function alone: In the Ventilation mode (fan rotation), press and hold the ventilation key does not release, first press the key on air conditioning, air conditioning light is lit, and then click the warm key, warm light is lit, all three lights lit, loosen the ventilation key, the oil pump began to pump oil (4Hz), three lights flashing at the same time, press any key to stop the pump oil. Three minutes after the automatic stop pump oil.

7.2 Trial operation is necessary for the heater before it is put into normal use. At trial operation, you have to check leakage from all connections and all safety issues. If discharge of dense smoke is observed or irregular combustion noise or fuel smell is sensed, the heater must be turned off. Please take out the fuse, making the heater unable to operate. The heater can only be put into use after it is tested by qualified professionals.

7.3 Before each heating season, check shall be performed by qualified professionals for maintenance works, details as follows:

- (a) Check air inlet and air outlet to find any pollution or foreign matters.
- (b) Clean the external of the heater.
- (c) Check if there is any corrosion or loose connection for electric contacts.
- (d) Check to find any clogging and damage to the air inlet pipe and exhaust pipe.
- (e) Check to find any leakage on the fuel pipe.

7.4 If the heater will not work for a long time, you'd better run it once every four weeks and let it run for 10 minutes at least to prevent malfunction of mechanical parts.

7.5 The air inlet port and air outlet vent of the heater must be kept clean and unblocked to provide smooth route for air flow, so as to prevent overheating.

7.6 If fuel is replaced with low-temperature fuel, run the heater for at least 15 minutes to fill new fuel into the fuel pipe and fuel pump.

7.7 When fill fuel for the heater, you have to turn off the power first. To do this, just turn the control switch anticlockwise to position "0".

7.8 The heat exchanger of the heater cannot work for longer than 10 years.

When it has worked for ten years, it must be replaced with a qualified one. The replace work must be performed by the heater manufacturer or its authorized agent. At

this time, the overheating sensor shall be replaced too.

7.9 The exhaust pipe of the heater for discharge of waste gas after combustion, if arranged in an area with passengers, shall be replaced with qualified one when it has worked for 10 years.

7.10 If electric welding is performed to the vehicle, please detach the positive wire of power supply of the heater from the battery and connect it to earth to protect the controller from any damage.

7.11 The ambient temperature shall be in the range of $-40^{\circ}\text{C}\sim 85^{\circ}\text{C}$ for transport and storage of the heater to avoid any damage to its electronic elements and components.

7.12 Only authorized customer service stations are allowed to provide repair and installation for the heater. It is prohibited to make repair by yourself or use non-manufacturer's parts or components so as to avoid danger.

7.13 The manufacturer shall not be held responsible for any damage to the heater if the heater is opened without authorization or such damage is caused due to installation or operation with violation against the regulations.