

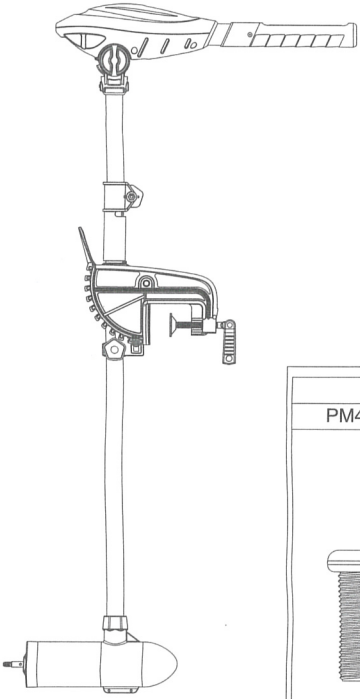



1852

MAR
INER
QUA
LITY

Instruction manual
for 40 LBS and 55 LBS

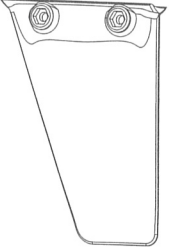
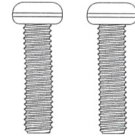
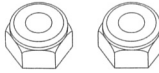
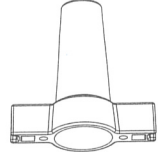
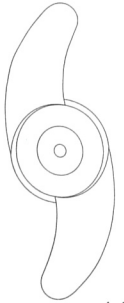
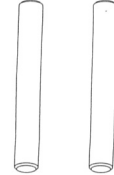
Packing List 40/55 LBS

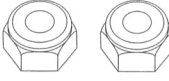
Trolling Motors		Instruction manual		Motor fin	
					
		1 Pcs		1 Pcs	
PM4x14 screws		M4 nuts		Propeller Wrench	
					
2 Pcs		2 Pcs		1 Pcs	
Propeller	Drive pin	Sacrificial Anode	Ø18XØ8.2X1 Washer	M8 nuts	
					
1 Pcs	2 Pcs	2 Pcs	2 Pcs	2 Pcs	

Before the operation

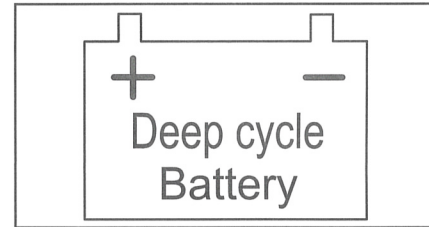

Please use deep cycle battery for your motor. Improper use of battery would cause damage to the motor.

Make sure the motor is off during the onshore period.

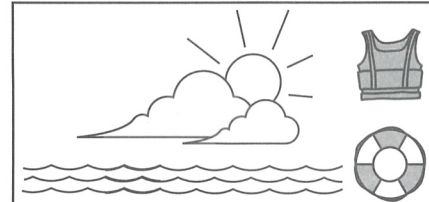

Please make sure the motor is off (handle on neutral), before connecting the battery.

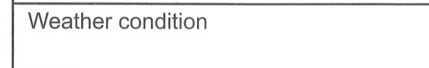

Personal life-jacket is needed at all time. And choose a good weather for your outdoor activity.

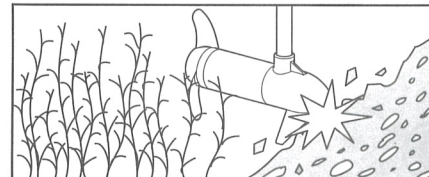

Beware the underwater condition

Turn the motor off (handle on neutral) to slow down the boat's speed. Tilting the motor to prevent impact when entering the shallow water area.

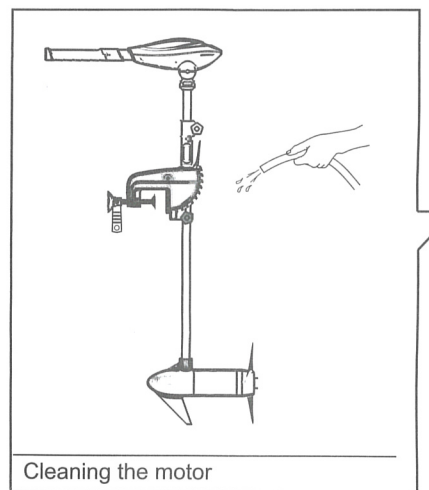

Cleaning the motor

Beware of the swimmer and your surrounding during the operation.

Remove sundries from the propeller and wash off the motor, especially after the saltwater use.

CAUTION

IP65 waterproof level for general.
IP68 waterproof level for the motor.

1 Installing the propeller

WARNING Make sure the motor is disconnected from the battery before installing or replacing the prop.

NOTE Use the propeller wrench supplied or 7mm wrench for the installation. (The use of inappropriate tools may cause motor damage)

1. Install the drive pin into the shaft hole and align it with the propeller (The drive pin and the propeller groove must align horizontally). Once the propeller is in place install the Sacrificial Anode, stainless washer and nut into the shaft. (figure.1)

NOTE The cross-shaped groove (2 grooves) allow user to reassemble the propeller if one groove is worn off.

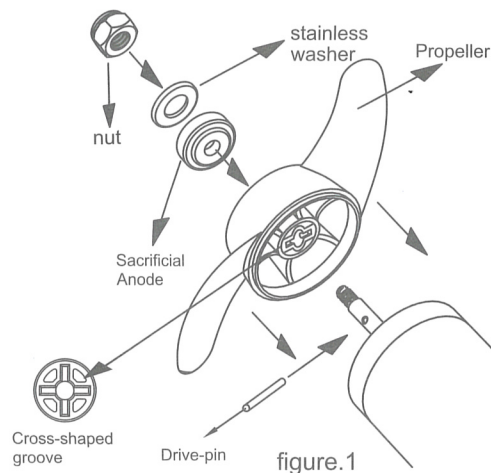

2. Hold the propeller to prevent it from revolving and use the propeller wrench to tighten the propeller nut. (figure.2)

NOTE If replace or detach the propeller. Please follow the above instruction steps and procedure it conversely.

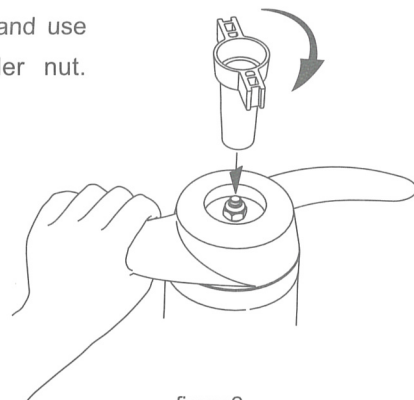

figure2

2 Mounting the trolling motor

WARNING Make sure the motor is battery disconnected during the mounting and dismounting or onshore period.

Mounting the trolling motor on the centerline of the boat, tighten the clamp screws. (figure.3)

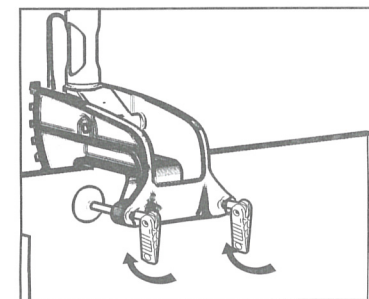
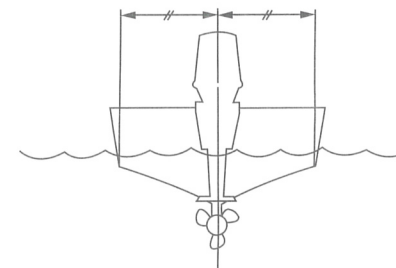

figure.3

3 Battery connection and power reader

WARNING Make sure the motor is off (handle on neutral), while connecting the battery.

1. Battery connection

Select a compatible battery --- Please use deep cycle battery for your motor. Improper use of battery would cause damage to the motor.

Connecting the battery - connect the red motor cable (+) to the positive battery terminal (+), black cable (-) to the negative terminal and fasten it. (figure.4)

Put the battery in a ventilated place.

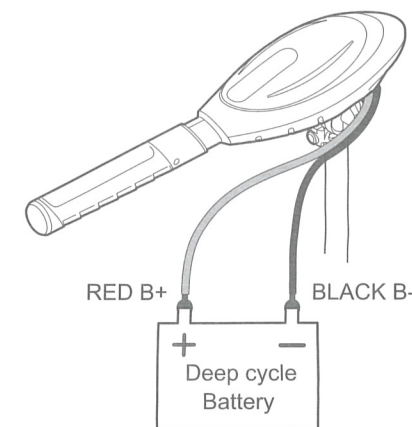

figure.4

2. Power reader

The motor has a power reader to display a real time battery level. Full light indicates a full power charge condition. The light will go off when the power is continue to decline. Please recharge the battery when it reduces to 20%. (figure.5)

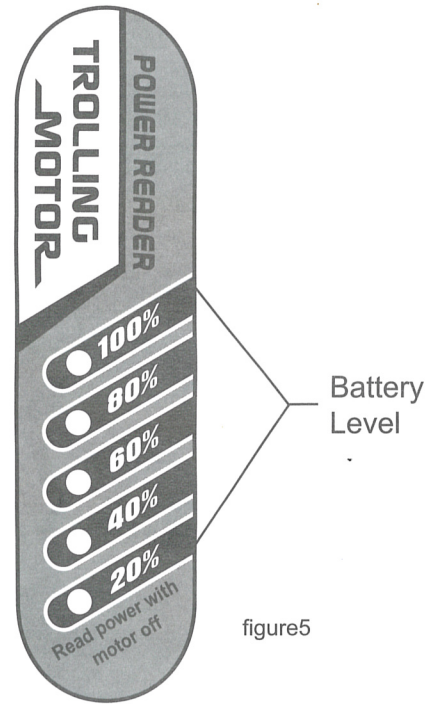

figure5

4 Motor Fin Installation

Aligns the motor-fin on the motor, install it with two fin-screws. (figure.6)

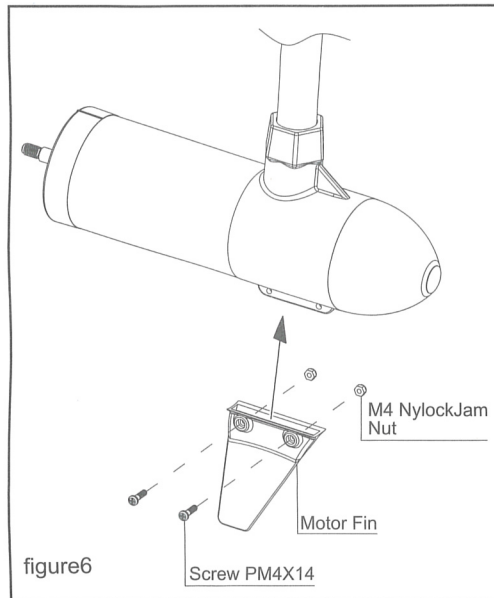

figure6

How to operate the motor

1. Tilting the motor

Hold the motor shaft with one hand and depress the tilting lever with other hand. Adjust the motor to a desired angle then release the tilting lever to lock it. (The motor has a 10 tilting levels) (figure.7)

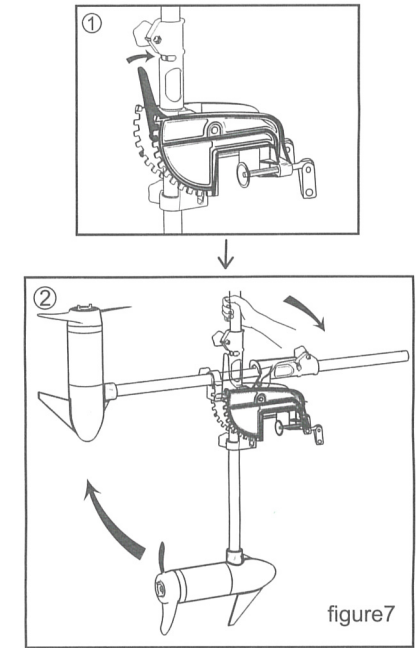

figure7

2. Trolling motor handle

This trolling handle has the folding and telescoping functions. Adjust the desired control position simply by pulling and pushing the handle (folding angle: 110°, extended length: 350mm). User can also adjust the folding knob to stabilize the angle position. (figure.8)

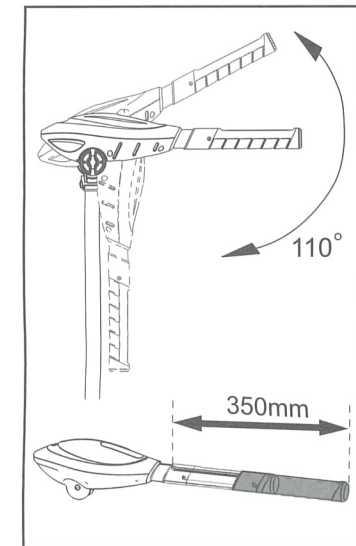

figure8

3. Speed control

The speed controller is integrated in the handle. It offers 5 levels of forward speed and 3 levels of reverse speed. Turning the handle to the neutral position will shut down the motor from running. (figure.9)

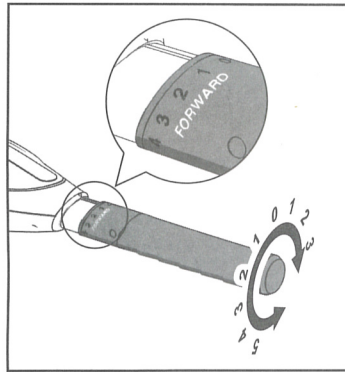

figure9

4. Tension the steering

Loosen the steering tension screw, set the motor to a desired direction and fasten it again. (figure.10)

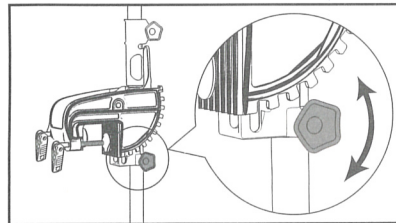

figure10

5. Adjust the motor depth

Steady the motor shaft and set the depth collar to a desired position then secure it. Loosen the steering tension screw and deploy the motor carefully. (figure.11)

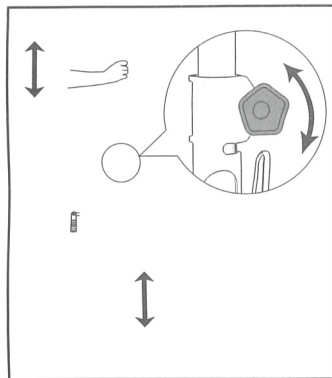

figure 11

Trouble shooting and solving method

1. Motor fails to run or lack of power

Make sure the motor cable is connected properly.

Check if the cable terminals clean and corrosion free.

Make sure the battery is full . Please recharge it when the battery is empty.

Make sure there is no fishing line or weeds caught up in the propeller. Please detach and clean up the propeller if there is sundries got caught inside the prop. (WARNING :

Make sure the motor is disconnected from the battery)

2. Hard to steering

Check if the steering tension screw is loosened.

Clean the motor shaft and apply lubricant to the fasteners and turning parts.

Make sure the underwater condition is fine and nothing blocks the way.

3. Motor vibration

Make sure the propeller is installed properly.

Inspect the propeller and the drive pin conditions, replace it if necessary.

Disconnect the battery cable and examine it by turning the propeller manually, motor shall turn freely with a slight magnetic drag. Internal damage might occur if motor is blocked or locked. Stop use it and contact our customer service.

Electric circuit diagram

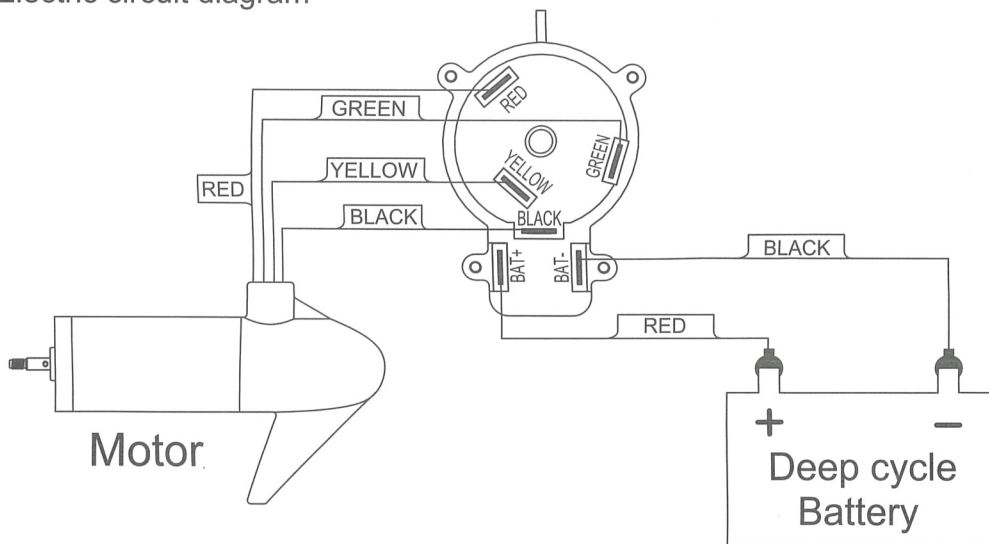

Contents

Product's features	01
Before the operation	02
Installation	
① Installing the propeller	03
② Mounting the trolling motor	04
③ Battery connection	04-05
④ Motor Fin Installation	05
How to operate the motor	06-07
Trouble shooting and solving method	08-09
Electric circuit diagram	09
Maintenance	10
Packing list 40/55 LBS	11-12

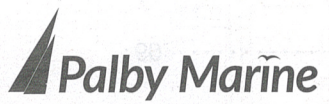

Palby Marine A/S
Korsvej 3 · 6000 Kodling · Denmark
Tel: +45 75 88 13 11
www.palby.dk