

Notes: -
For marine applications, use a silicone sealant or a bedding compound to avoid electrolytic action between the cleat and metal fastenings.

2 Holes Ø6.5
countersunk Ø13.7x90°

Section 'AA'

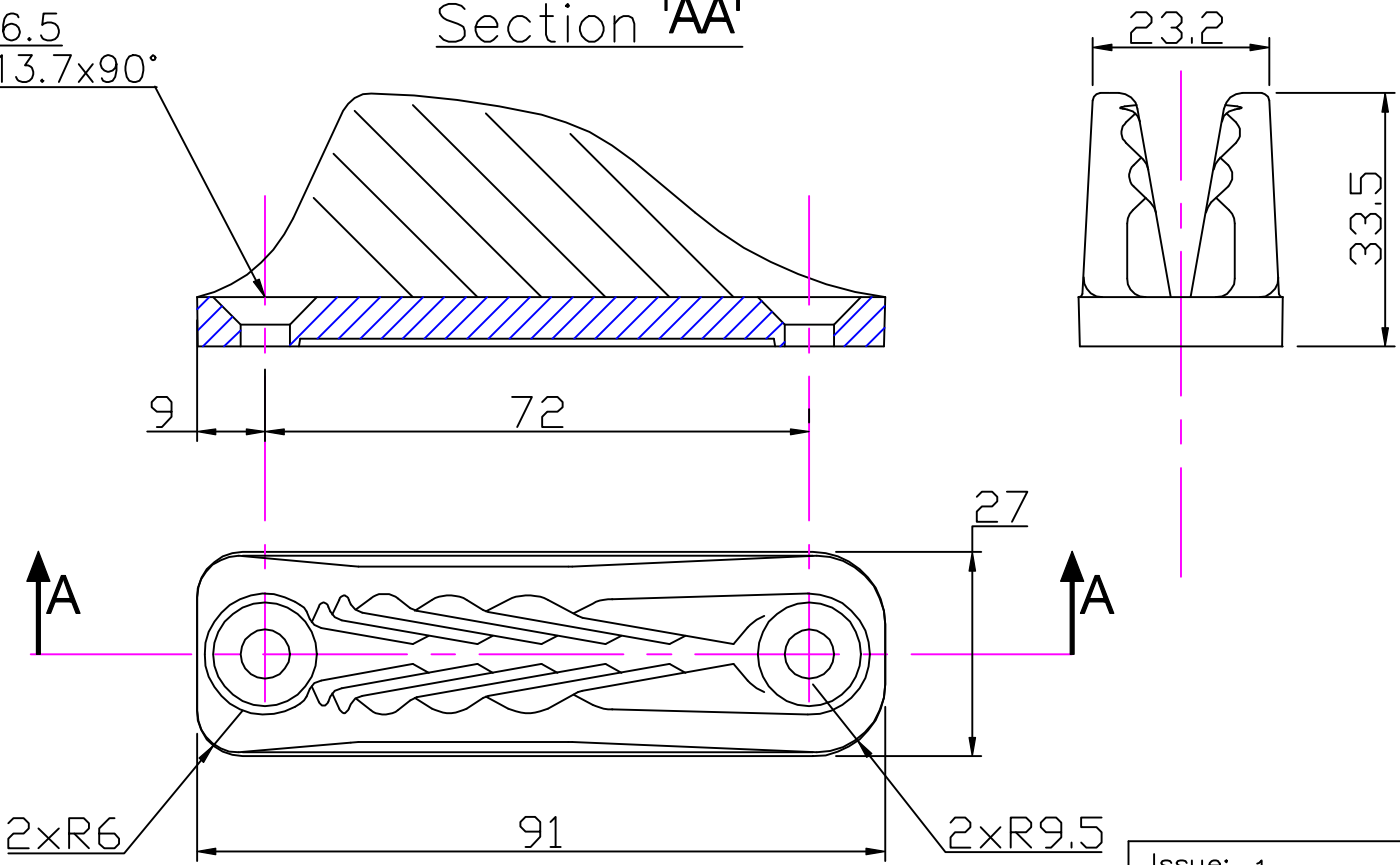

Clamcleat®
Rope cleats

Clamcleats Limited
Watchmead
Welwyn Garden City
Hertfordshire AL7 1AP
England

Telephone +44 (0)1707 330101
Fax +44 (0)1707 321269
<http://www.clamcleat-rope-cleats.com>

Scale 1:1
All dimensions in mm.

Issue: 1.	Apr 1999
ID219.dwg	
Material: Diecast Aluminium	
Installation Drawing for:- CL219 Racing Vertical	