

# JABSCO

## MODEL 37004-1000

a xylem brand

### ELECTRIC TOILET BASE

This Electric Toilet-Base Kit will update all early model Jabsco Electric Toilets to the current more stylish and easier to clean toilet design. It should be noted that while the base is about 1/2" larger in diameter, the base mounting screw holes on either side remain in the same location. In most applications the two side hold-down fasteners should be adequate to secure the base in place. However, for slightly more security, since the two rear attachment points on the old base design are no longer utilized, an additional forward fastening point has been added. 1/4" (6 mm fasteners) are generally sufficient to secure the base in place.

**WARNING**  
 **Flood hazard. Close inlet and outlet seacocks prior to disassembling toilet. Failure to do so can result in flooding which can cause loss of property and life.**

**NOTICE:** Before performing any service, disconnect the power supply to the toilet and take precaution to ensure it is not reconnected until the service is completed.

### BASE INSTALLATION

**A.** Remove the toilet with old base from its mounting surface. Remove the bowl to base attachment fasteners and lift the bowl from the old base. Remove the four screws that secure the pump assembly to the base (retain the screws and washers for re-use) and slide the assembled pump out of the base. The chopper will engage the black macerator housing and it may be necessary to gently "tap" the chopper against it to dislodge the macerator housing from the base. The old base with its attached discharge port, base to bowl rubber gasket and attachment fasteners are not used with the new base kit.

**B.** Slide a 6 mm lock washer (internal tooth) (Key 2) onto each of the 6 mm (Phillips) Pan Head machine screws (Key 1). Place a 6mm hex nut (Key 3) into a hex shaped pocket on the top of the base at each attachment point. From the bottom side of the base, insert a 6mm machine screw with lock washer through the base attachment hole and screw it into the nut in the pocket on the top of the base. Repeat this process and torque each screw to 23-25 inch pounds, until the four attachment screws form mounting studs to attach the china bowl.

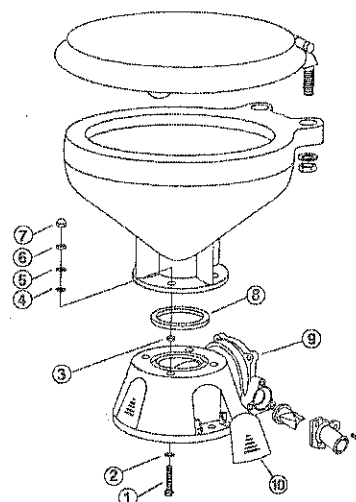

Model 37004-1000

**C.** Ensure the black macerator housing (around the chop per and centrifugal waste pump impeller) is properly aligned, with the discharge cutout positioned at the discharge port and the raised positioning rib at the top aligning with the notch in the top of the base. Ensure the pump sealing O-Ring (gasket on very early models) is properly positioned in its groove (a little grease may be used to hold it in place) and carefully (so as not to dislodge the seal) slide the pump assembly into the base. Secure the pump to the base with the four machine screws and lock washers and torque each to 13-15 inch pounds.

**D.** It is generally easier to re-attach the base and pump assembly to the sole (floor) and complete the plumbing and electrical connections prior to securing the china bowl to the base. If adding a forward attachment fastener and if using lag screws into a gelcoated surface, it is best to drill a fastener clearance hole through the gelcoat to avoid cracking it. After securing the base in place, snap each fastener cover (Key 10) into its lock at each hold-down fastener alcove.

**E.** Once the base and pump assembly is secured in place, position the bowl/base O-Ring (square cut) seal (Key 8) in the O-Ring groove on the top of the base. Ensure the bottom of the china bowl is clean and position the bowl over the base studs onto the base. Place a plastic washer (Key 4) over each stud to protect the surface of the china bowl, then place a stainless steel washer (Key 5) on top of each plastic one. Screw a 6mm hex nut (Key 3) onto each stud and torque each to 23-25 inch pounds. Place one white plastic decorative cap (Key 7) on top of each 6mm hex nut. Re-attach all hoses and electrical connections (if not done previously) that may have been removed.

[www.xylem.com](http://www.xylem.com)

# xylem

Let's Solve Water

**UK**  
**Xylem**  
Bingley Road, Hoddesdon  
Hertfordshire EN11 0BU  
Tel: +44 (0) 1992 450145  
Fax: +44 (0) 1992 467132

**USA**  
**Xylem**  
100 Cummings Center Drive  
Suite 535-N, Beverly, MA 01915  
Tel: +1 978 281-0440  
Fax: +1 978 283-2619

**ITALY**  
**Xylem**  
Via Tommaseo, 6  
20059 Vimercate, Milano  
Tel: +39 039 685 2323  
Fax: +39 039 666 307

**GERMANY**  
**Xylem**  
Oststrasse 28  
22844 Norderstedt  
Tel: +49-40-53 53 73-0  
Fax: +49-40-53 53 73-11

**CHINA**  
**Xylem**  
32/f Tower A, Hongqiao, City  
Centre of Shanghai, 100 Zunyi  
Road, Shanghai, 200051  
Tel: +86-21-2208-2888  
Fax: +86-21-2208-2999

Warranty: All products of the company are sold, and all services of the company are offered subject to the company's warranty and terms of sale, copies of which will be furnished upon request. Details correct at time of printing. We reserve the right to change specifications without prior notice.

© 2018 Xylem, Inc. All rights reserved. Jabsco is a trademark of Xylem Inc. or one of its subsidiaries.

43000-0732 REV B 2/2018