



a xylem brand

REMOTE CONTROL SEARCHLIGHT FEATURES

- Constructed of noncorrosive materials
- Sealed beam halogen lamp
- Remote control and 15' cable included
- Long life gear drive
- Low amp draw
- Patented clutch mechanism prevents motor damage when running against limit stops

APPLICATION

Ideal for boaters...locate buoys, moorings, channel markers, etc. Ideal for RV'ers...pinpoint road signs, campsites, or use as backup light.

SPECIFICATIONS

- 360° horizontal movement
- 75° vertical sweep
- White thermoplastic housing and base

INSTALLATION INSTRUCTIONS

LIGHT MOUNTING

1. Select a location for the light which will allow for clear beam projection. Searchlight base should be mounted on level, flat surface.
2. Using the light base mounting template enclosed, drill three pilot holes and a cable exit hole. Fasten hold down bracket on to mounting surface with screws provided, or applicable screws for your application.
3. Peel off adhesive backing from gasket and place on light mounting base with the adhesive side on the base. Feed cable through cable exit hole.
4. Slide light base on to hold down bracket while pushing down on base, making sure metal strip on light base engages the hold down bracket. Fasten screw on the outside of the base to seal the base against the surface.

NOTE: Secure cable with nylon clips or equivalent. Protect installation at points of stress and leave adequate slack where cable must be flexible.

	WARNING Burn Hazard. Do not touch lense when light is on. Do not operate with storage cover over light.
---	---



Model 61050-0012

Remote Control Unit

CONTROL INSTALLATION

Select the best location near the helm which will allow for convenient operation of control.

1. Cut two holes (see Panel Cutout Template enclosed) for mounting control.
2. Route power leads (supplied by customer) from voltage source to control. Note: Wiring must be 16 gauge (minimum).
3. Connect positive (+) power lead to red (+) wire and negative (-) power lead to black wire using butt connectors. Be sure fuse holder in positive lead has the proper size fuse installed.
4. Plug connector from control panel to end of light cable connector.
5. Use bedding compound or sealant to waterproof control mounting.
6. Secure control with self-tapping screws provided.

CIRCUIT PROTECTION

A 10 amp fuse has been included in the fuse holder. Should this fuse blow, replace with the same size fuse after determining reason for blown fuse.

Model Number	Voltage	Amps	Fuse/Breaker	Candlepower	Weights lb (kg)	Standard Carton
61050-0012	12V DC	4.5	10	100,000	5 (2.3)	4

DUAL STATION INSTALLATION KIT 43670-0004

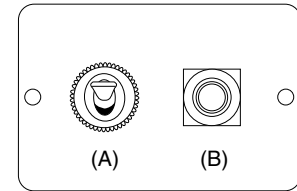
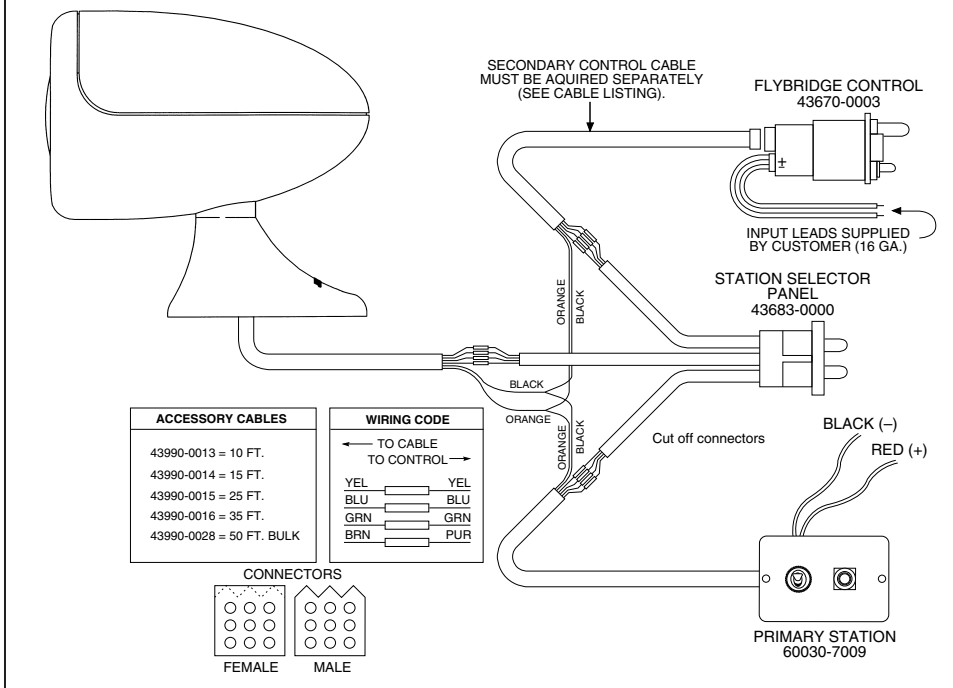

CONTROL UNIT OPERATION

SWITCH FUNCTIONS

(A) Light Switch

On/Off switch positions.

(B) Directional Switch

Lever has eight contact positions and will operate in horizontal, vertical, and in four combinations of directions.

CLEANING OF EXTERIOR PLASTIC SURFACES

Recommendation for cleaning "Exterior Surfaces" is a solution of warm water and a mild detergent soap.

CAUTION Do not use cleaners that contain esters, halogenated solvents, aromatic solvents, ketones and strong acids or bases.

SERVICE

BULB REPLACEMENT

1. Remove light cover by removing screw from the rear of the light housing.
2. Pull the bulb assembly from the light housing and remove rubber seal around the bulb to separate the bulb from bulb housing.
3. Unscrew terminals from bulb and connect terminals to new bulb.
4. Replace seal ring and place bulb assembly in to the light housing. Fasten cover with screw.

TROUBLESHOOTING

All lights are thoroughly inspected before shipping and are warranted to operate within specifications. If light does not operate correctly, check fuse and wire harness connections before proceeding.

Problem

Solution

Control works in reverse in all directions.	Control installed upside down.
Bulb operates – no light movement.	Check wiring code for proper wire color connections.
Light moves – bulb does not operate.	1. Check bulb.
Dim light	1. Check voltage at power source. 2. Check wire size from source to control and for proper ground circuit.

PARTS LIST

Description	Part Number
Bulb Kit w/Seal Ring	18753-0528
Directional Switch	43990-0000
On/Off Switch	18753-0180
Control (Complete)	60030-7009

CONTROL REPLACEMENT

Individual replacement parts are available for the control panel. To replace switches remove the two (2) screws from front of panel and pull forward, exposing wiring.

1. To remove directional switch push firmly on the front toggle and remove switch from back side of panel. Defective switch, and splice wires (with butt connectors) to the new switch, being sure to match wire colors. Note: Install switch with yellow wire on top for correct directional aiming.
2. To remove On/Off switch, unscrew ring on face of switch body and remove switch from panel. Connect wires to new switch the same as old switch and install switch.

MOUNTING TEMPLATE
(Light Base)

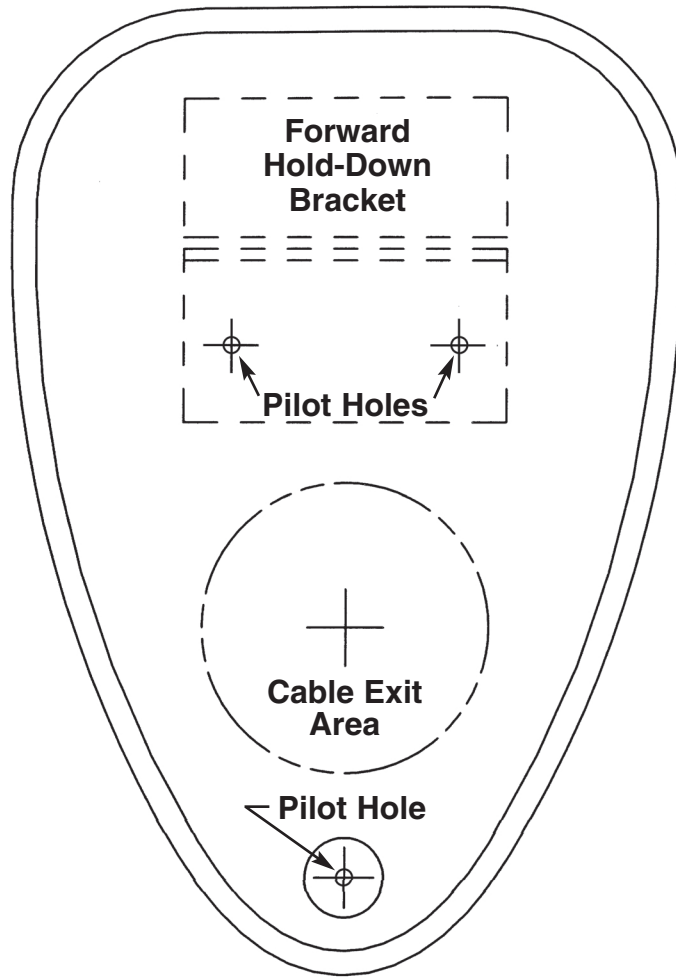

PANEL CUTOUT
(Control Unit)
Inches (Millimeters)

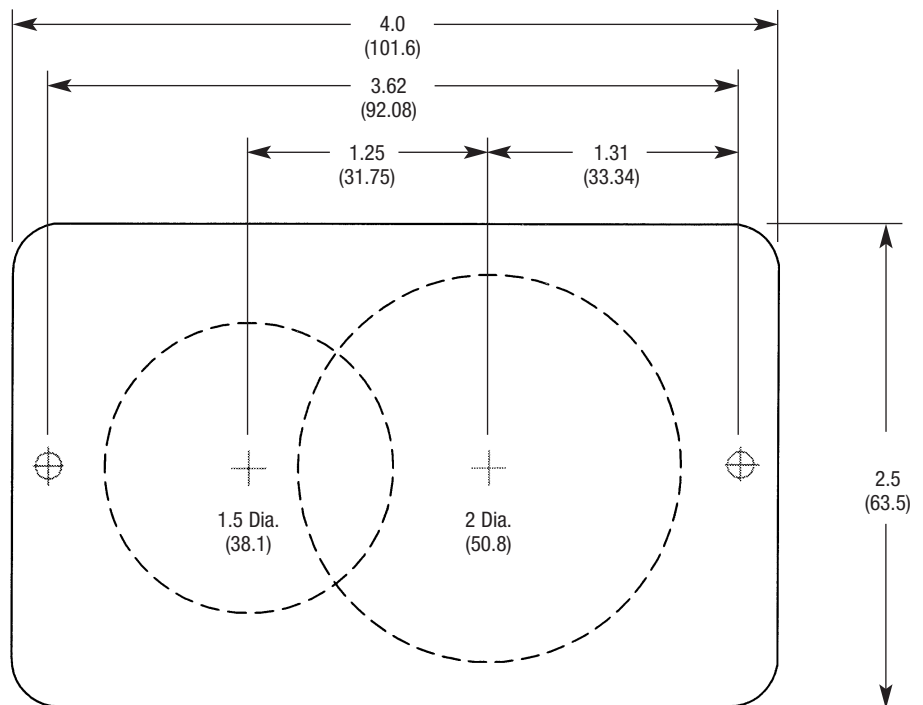

DIMENSIONAL DRAWING

Searchlight Inches (Millimeters)

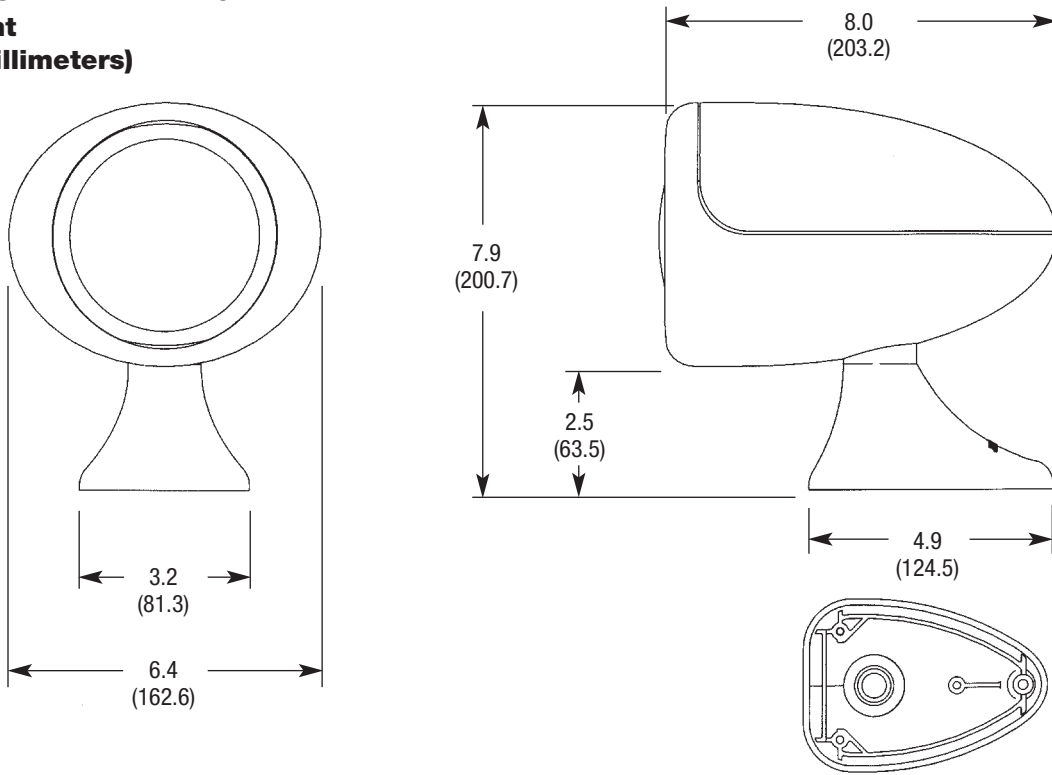

CONTROL UNIT

Inches (Millimeters)

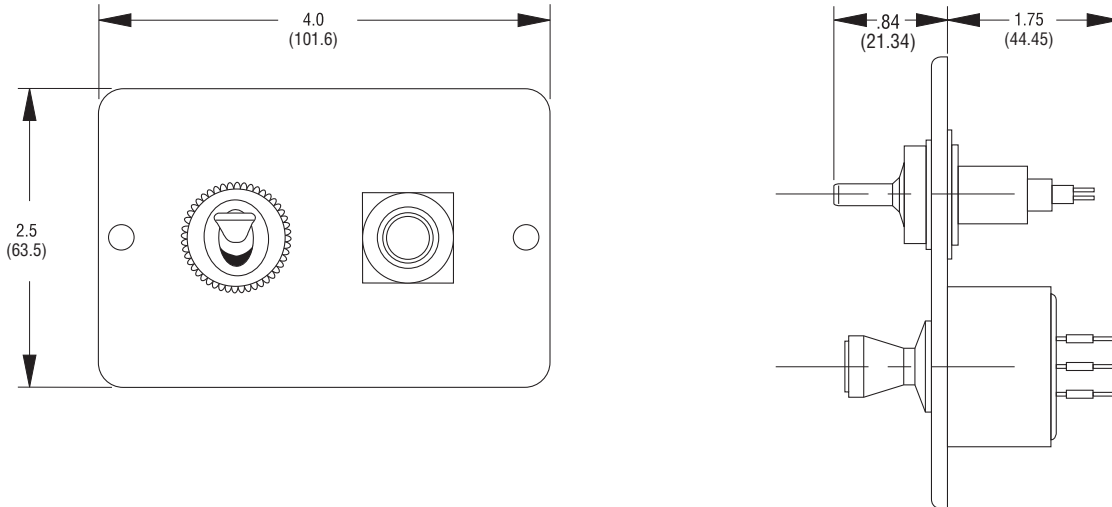

THE PRODUCTS DESCRIBED HEREIN ARE SUBJECT TO THE JABSCO ONE YEAR LIMITED WARRANTY, WHICH IS AVAILABLE FOR YOUR INSPECTION UPON REQUEST.

www.xylemflowcontrol.com

Jabco, 100 Cummings Center, Ste. 535-N, Beverly, MA 01915
 Tel: +1 978 281 0440 Fax: +1 978 283 2619

Jabco, Bingley Road, Hoddesdon, Hertfordshire, EN11 0BU
 Tel: +44 (0) 1992 450 145 Fax: +44 (0) 1992 467 132

NHK Jabco Co Ltd, 3-21-10, Shin - Yokohama Kohoku-ku, Yokohama 222
 Tel: +81 (0) 45 475 8906 Fax: +81 (0) 45 475 8908

Jabco GmbH, Oststraße 28, 22844 Norderstedt
 Tel: +49 (0) 40 53 53 73 0 Fax: +49 (0) 49 53 53 73 11

Jabco Italia, s.r.l., Via Tommaseo, 6, 20059 Vimercate, Milano
 Tel: +39 039 685 2323 Fax: +39 039 666 307

USA

UK

JAPAN

GERMANY

ITALY



a xylem brand